



**JBL**

**PROFESSIONAL**

**VTX SERIES**  
SYSTEM SOLUTIONS

## **VTX B28 | Rigging Manual**

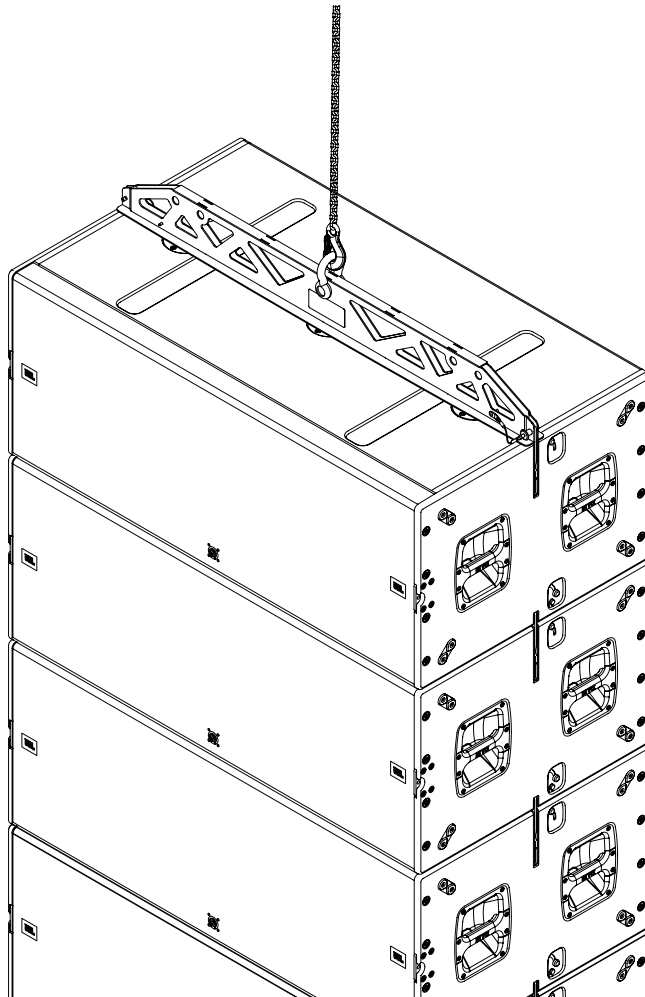

**GENERAL INFORMATION**

VTX B28 - Rigging Manual

Document Number: 1000346380

Version: A - EN

Distribution Date: July 13, 2020

Copyright © 2020 by HARMAN International; all rights reserved

**JBL PROFESSIONAL**

8500 Balboa Blvd

Northridge, CA 91329

USA

Thank you for purchasing JBL VTX Series products



In more than 75 years of JBL innovations, the VTX Series stands apart as a milestone in the practical application of creative engineering. VTX products herald the next generation in line array loudspeaker systems: a new era in performance, system integration and user friendliness. VTX products draw on multiple JBL patents in driver, waveguide, and suspension technology, as well as custom amplification, DSP, control, and system management designs created in collaboration with HARMAN Professional sister companies.

VTX loudspeakers marry custom transducer design and in-house manufacture, breakthrough technologies, and a comprehensive system approach to deliver a premium experience for all who come into contact with it, from the FOH mixing engineer to the systems engineer, rigger, road crew, warehouse manager, and, of course, the audience. Designed for operators of portable and fixed systems alike, the VTX Series features JBL's legendary sound quality coupled with expert support and advanced tools that enable optimal specification, configuration, and operation of VTX systems in any venue, anywhere in the world. The VTX Series delivers a comprehensive solution: the finest sound quality available, plus efficient and intuitive setup, tuning, networking, and control.

## TABLE OF CONTENTS

<b>1 - SAFETY</b> .....	<b>6</b>
1.1 Safety Instructions .....	6
1.2 General Hardware Information .....	6
1.3 Attachment to Structures .....	6
1.4 Important Safety Warning .....	7
1.5 Are You New to Rigging? .....	7
1.6 Inspection and Maintenance .....	7
1.7 Symbols .....	8
<b>2 - MECHANICAL LIMITS</b> .....	<b>9</b>
2.1 VTX B28 Limits - Suspended Array .....	9
<b>3 - SYSTEM COMPONENTS</b> .....	<b>10</b>
<b>4 - SOFTWARE</b> .....	<b>11</b>
4.1 Line Array Calculator 3™ .....	11
4.2 Array Link™ .....	12
4.3 Ground-Stacked Arrays in LAC-3 .....	13
<b>5 - RIGGING SYSTEM</b> .....	<b>14</b>
5.1 Overview .....	14
5.2 The Rigging Mechanism .....	15
5.3 Connecting Cabinets Together .....	17
5.4 Locked and Unlocked Example .....	18
<b>6 - TRANSPORTATION OPTIONS</b> .....	<b>19</b>
6.1 Rotating the Dolly Tabs For Use With the ACC Dolly .....	20
<b>7 - VTX B28 ACC DOLLY OVERVIEW</b> .....	<b>21</b>
7.1 Attaching the VTX B28 ACC Dolly .....	22
7.2 Stacking the ACC Dolly Boards .....	23
7.3 Truck Packing with ACC .....	24
<b>8 - THE VERTICAL TRANSPORTER</b> .....	<b>25</b>
8.1 - VTX B28 VT Overview .....	25
8.2 Installing VTX B28 Cabinets on the VT .....	26
8.3 VTX B28 VT CVR .....	27
8.4 Stacking the VTX B28 VT .....	28
8.5 Truck Packing with VT .....	29
<b>9 - THE VTX B28 SUSPENSION BAR</b> .....	<b>30</b>
9.1 Suspension Bar Overview .....	30

9.2 Suspending B28 Arrays .....	31
9.3 Disassembling Arrays .....	34
9.4 Suspension Bar Use cases .....	36
9.5 Suspension Bar Safety Points .....	36
<b>10 - THE VTX B28 GND .....</b>	<b>37</b>
10.1 Attaching the VTX B28 GND .....	37
10.2 VTX B28 GND Examples .....	38
<b>11 - THE VTX A12 VT GND .....</b>	<b>39</b>
11.1 Attaching the VTX A12 VT GND .....	39
11.2 VTX B28 GND + VTX A12 VT GND Examples .....	41
<b>12 - USING THE M20 POLE MOUNT ATTACHMENT .....</b>	<b>42</b>
<b>13 - SPECIFICATIONS .....</b>	<b>43</b>
13.1 VTX B28 SB .....	43
13.2 VTX B28 ACC .....	44
13.3 VTX B28 VT .....	45
13.4 VTX B28 GND .....	46
<b>14 - CONTACT INFORMATION .....</b>	<b>47</b>

## 1 - SAFETY

### 1.1 SAFETY INSTRUCTIONS

1. Read these instructions.
2. Keep these instructions.
3. Heed all warnings.
4. Follow all instructions.
5. Do not expose the product to direct rain or sea spray.
6. Clean only with a dry cloth.
7. Do not install near any heat sources such as radiators, heat registers, stoves, or other apparatus that produce heat.
8. Only use attachments/accessories specified by the manufacturer.
9. Use only with a cart, stand, tripod, bracket, or table specified by the manufacturer or sold with the apparatus. When a cart is used, use caution when moving the cart/apparatus combination to avoid injury from tip-over.
10. Refer all servicing to qualified service personnel. Servicing is required when the apparatus has been damaged in any way, such as if liquid has been spilled or objects have fallen into the apparatus, or if the apparatus has been exposed to rain or moisture, does not operate normally, or has been dropped.
11. Contact JBL Professional for advanced servicing issues.
12. **CAUTION - DO NOT PERFORM ANY SERVICING UNLESS YOU ARE QUALIFIED TO DO SO.**
13. Prolonged exposure to excessive SPL can cause hearing damage. The loudspeaker is easily capable of generating sound pressure levels (SPL) sufficient to cause permanent hearing damage to performers, production crew, and audience members. Caution should be taken to avoid prolonged exposure to SPL in excess of 90 dB.
14. Read the System Rigging Manual before installation and use of the product.

### 1.2 GENERAL HARDWARE INFORMATION

Any hardware used in an overhead suspension application must be load rated for the intended use. Generally, this type of hardware is available from rigging supply houses, industrial supply catalogs, and specialized rigging distributors. Local hardware stores do not usually stock these products. Compliant hardware will be referenced with a working load limit (WLL) and a traceability code.

### 1.3 ATTACHMENT TO STRUCTURES

A licensed Professional Engineer must approve the placement and method of attachment to the structure prior to the installation of any overhead object. The following performance standards should be provided to the Professional Engineer for design purposes: Uniform Building Code as applicable, Municipal Building Code as applicable, and Seismic Code as applicable. The installation of the hardware and method of attachment must be carried out in the manner specified by the Professional Engineer. Improper installation may result in damage, injury, or death.

## 1.4 IMPORTANT SAFETY WARNING

The information in this section has been assembled from recognized engineering data and is intended for informational purposes only. None of the information in this section should be used without first obtaining competent advice with respect to applicability to a given circumstance. None of the information presented herein is intended as a representation or warranty on the part of JBL. Anyone making use of this information assumes all liability arising from such use.

All information presented herein is based upon materials and practices common to North America and may not directly apply to other countries because of differing material dimensions, specifications, and/or local regulations. Users in other countries should consult with appropriate engineering and regulatory authorities for specific guidelines.

Correct use of all included hardware is required for secure system suspension. Careful calculations should always be performed to ensure that all components are used within their working load limits before the array is suspended. Never exceed the maximum recommended load ratings.

Before suspending any speaker system, always inspect all components (enclosure, rigging frames, pins, eyebolts, track fittings, etc.) for cracks, deformations, corrosion, or missing/loose/damaged parts that could reduce strength and safety of the array. Do not suspend the speaker until the proper corrective action has been taken. Use only load-rated hardware when suspending JBL suspendable loudspeaker models.

## 1.5 ARE YOU NEW TO RIGGING?

**If you are new to rigging, you should:**

- Know the rules for safe rigging.
- Attend a safe rigging seminar.
- Meet and establish a relationship with a licensed mechanical or structural engineer. Get in the habit of asking them questions instead of assuming their answers. Learn from what they tell you.
- Research and understand the codes, practices and requirements of the venues where you intend to operate your sound system.

## 1.6 INSPECTION AND MAINTENANCE

Suspension systems are comprised of mechanical devices and, as such, require regular inspection and routine maintenance to ensure proper functionality. Before suspending or pole mounting any speaker system, always inspect all components (enclosure, suspension frames or brackets, pins, eyebolts, etc.) for cracks, deformations, corrosion, or missing/loose/damaged parts that could reduce strength and safety of the array. Do not suspend or pole mount a speaker until the proper corrective action has been taken.

Installed systems should be inspected at least once a year. The inspection must include a visual survey of all corners and load-bearing surfaces for signs of cracking, water damage, delamination, or any other condition that may decrease the strength of the loudspeaker enclosure.

Accessory suspension hardware provided with or for VTX systems must be inspected for fatigue at least once a year or as required by local ordinance. The inspection must include a visual survey of the material for signs of corrosion, bending, or any other condition that may decrease the strength of the fastener. Additionally, any eyebolts must be checked for possible spin-out of the enclosure.

**For all other hardware and fittings, refer to the hardware manufacturer's inspection and maintenance guidelines for process.**

JBL is not responsible for the application of its products for any purpose or the misuse of this information for any purpose. Furthermore, JBL is not responsible for the abuse of its products caused by avoiding compliance with inspection and maintenance procedures or any other abuse.

Prior to suspending the system, an expert, trained and experienced in suspending speaker systems, should inspect all parts and components.

## 1.7 SYMBOLS

The following symbols are used in this document:



**CAUTION:** This symbol gives notice of a potential risk of harm to the individual or the equipment. Instruction marked with this symbol must be strictly followed.



**TIP:** This symbol gives notice of helpful, relevant information about the topic.



**INSTRUCTIONS:** This symbol gives notice of instructions that must be followed for proper installation and use of the product.



**TOOLS REQUIRED:** This symbol gives notice of tools that must be used for proper installation and use of the product.



## 2 - MECHANICAL LIMITS

The VTX B28 suspension system and accessories comply with the 2006/42/EC Machinery Directive and have been designed following the guidelines of DGUV regulation 17 (BGV-C1) for a minimum safety factor of 4:1. Minimum safety factor requirements for suspended arrays are often set by local regulations. Use the JBL Line Array Calculator™ software to check mechanical limits and ensure compliance with local regulations. ANSI Standard E1.8 (Entertainment Technology Loudspeaker Enclosures Intended for Overhead Suspension), Section 5.3.4, specifies a minimum safety factor of 5:1. If compliance with the ANSI standard is needed, make sure that the array design produces a minimum safety factor of 5:1.

### 2.1 VTX B28 LIMITS - SUSPENDED ARRAY

ARRAY FRAME	NOTES	SAFE LIMIT	MAXIMUM LIMIT
VTX B28 SB	Suspension Bar used as an Array Frame (top center)	(16) B28	(16) B28

#### TERMINOLOGY:

**Safe Limit:** The safe limit provides the number of cabinets that can be used in an array while maintaining a safety factor of 4:1 or higher. The safety factor of an array is determined by the number of cabinets, the array shape, and the overall array angle. An array constructed within the safe limit will always yield a safety factor greater than 4:1 regardless of array parameters and conditions. Ground-stacked arrays within the safe limit are stable under normal conditions. Designs exceeding the safe limit and up to the maximum limit, are possible, but the JBL Line Array Calculator™ software should be used to check mechanical safety for the given configuration.

**Maximum Limit:** Arrays larger than the maximum limit are not allowable under any conditions.

#### NOTES:

- When the safe limit and maximum limit are the same, the array always produces a safety factor of 4:1 or higher.
- Safe and maximum limits are only applicable to the specified accessory (i.e. base plate or array frame). When several accessories are combined (for example, ground-stacked arrays with a base plate and subwoofers underneath), the design should always be evaluated and checked with LAC-3.
- LAC-3 will not allow array designs below the 4:1 minimum safety factor.



**CAUTION:** Limits for ground-stacked arrays always assume that the stacking surface (floor or stage) is flat . Do not deploy ground-stacked arrays on non-flat surfaces to avoid tipping hazards .

### 3 - SYSTEM COMPONENTS

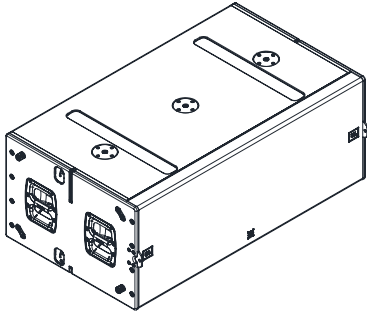

**VTX B28**

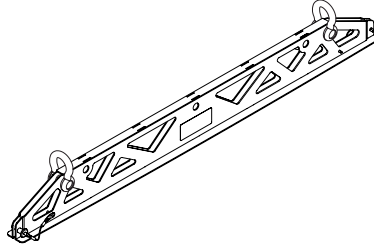

**VTX B28 SB | Suspension Bar**

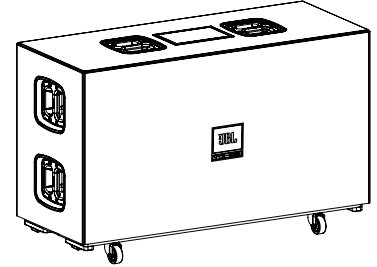

**VTX B28 ACC | Dolly Board & Cover**

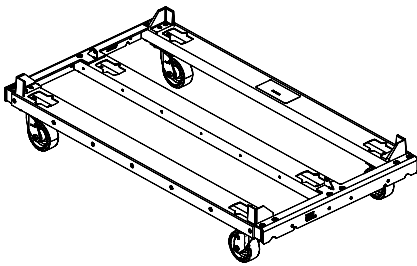

**VTX B28 VT | Vertical Transporter**

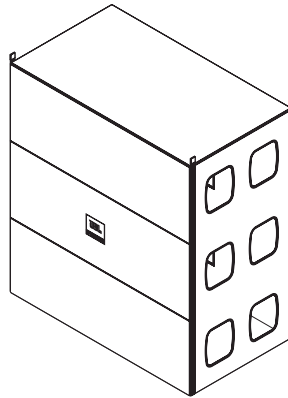

**VTX B28 VT CVR | Soft Cover**

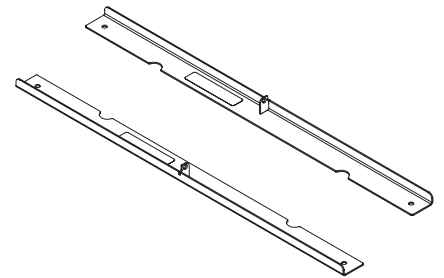

**VTX B28 GND | Ground Stack**

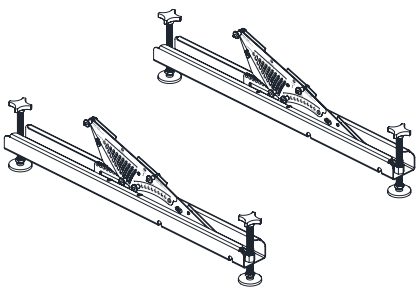

**VTX A12 VT GND | Ground Stack**



**CAUTION:** Always use components and accessories specified and approved by JBL Professional. When a cart is used, use caution when moving the cart to avoid injury from tip-over.

## 4 - SOFTWARE

### 4.1 LINE ARRAY CALCULATOR 3™

Line Array Calculator 3 acoustical prediction software is used for the design and mechanical validation of VTX series line array systems. Using LAC-3 is a three-step process. First, venue dimensions are defined using either X/Y/Z coordinates or the fast distance/angle method. Second, array configurations are built from VTX loudspeaker models. Third, virtual measurement microphones and a suite of built-in DSP functions are applied to make predictions of the system's coverage and the linearity that will be delivered by the defined array configuration in the specified space. Loudspeaker quantities and models, splay angles, and array aiming can be modified until prediction shows that the desired coverage is attained throughout the venue. The built-in coverage-and-delay calculator determines subwoofer delay values for electronic delay steering (EDS) that achieves optimal low frequency coverage.



Beyond acoustical predictions, LAC-3 validates the mechanical properties of arrays and selected JBL accessories. Configuration limits are calculated in real time, for either suspended or ground-stacked arrays, based on array parameters such as the number of cabinets, cabinet-to-cabinet splay angles, overall array aiming, and selected accessories. In the case of suspended arrays, a safety factor is calculated to aid in designing systems that conform to local regulations. Warnings and error messages notify the user when an array or a specific accessory is outside safe working limits. For ground-stacked arrays, a tipping factor calculated from a complex set of variables suggests whether an array design is likely to be stable, potentially unstable, or unsafe. Array statistics like array size, depth, and weight are also calculated, and a PDF report facilitates system deployment. Mechanical data can be transferred to JBL's Array Link™ app running on an iOS® or Android mobile phone using a QR code, with no need for Internet connectivity. All relevant rigging information and options are presented in an easy-to-understand layout.



**CAUTION: All VTX systems should be designed and validated using the LAC-3 software application. This is the only way to ensure that safe mechanical conditions are met for any given configuration.**

## 4.2 ARRAY LINK™

JBL Array Link is a mobile companion app that works with LAC-3 software to assist technicians deploying VTX Series systems in the field. Array Link uses a QR code to directly transfer mechanical data in real time from an array design created in LAC-3 to a mobile phone running iOS® or Android™. All relevant rigging information and options are presented in an easy-to-understand layout. The application can be downloaded free from the Apple App Store or Google Play Store.

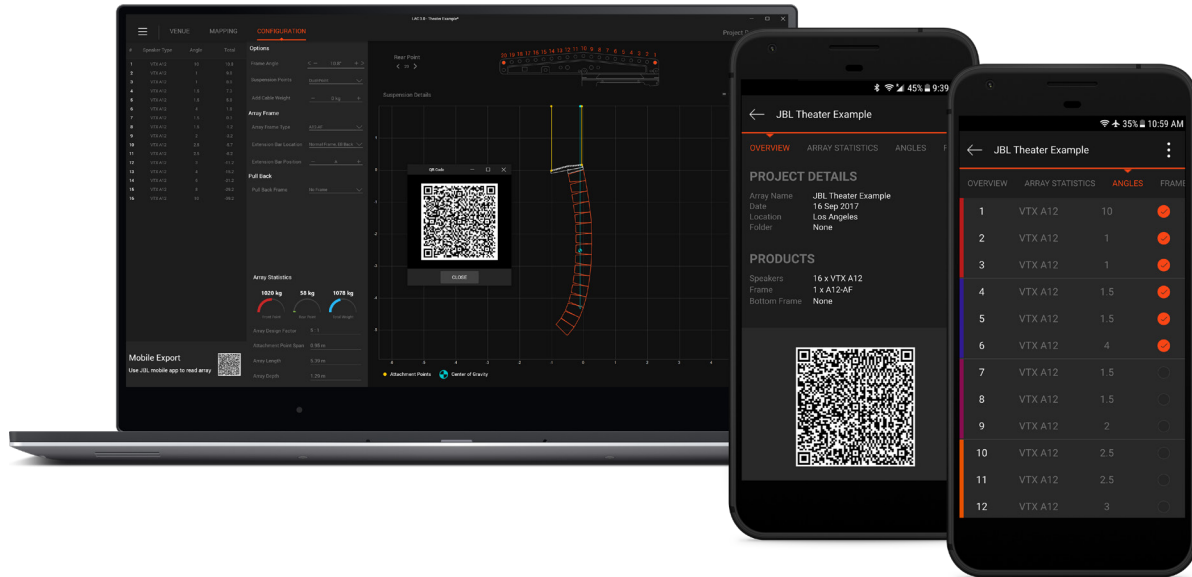

Once the system designer or lead tech computes the angles for each hang in LAC-3, every member of the crew can get the correct information for angles, attachment points, trim height, etc., either by scanning the QR code from LAC-3 directly with their device, or getting the data from a copy shared on another user's device. When all users onsite have the configuration data, arrays can be deployed quickly and efficiently.

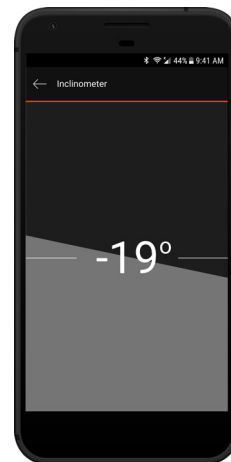
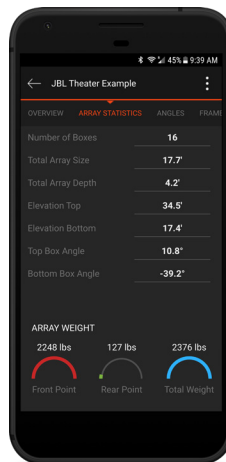
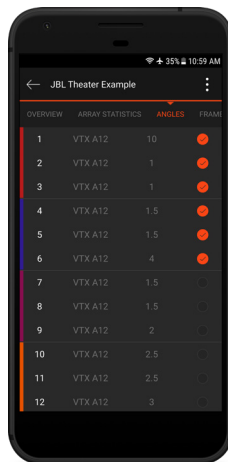

### 4.3 GROUND-STACKED ARRAYS IN LAC-3

Line Array Calculator version 3.5.0 or later includes mechanical safety checks for ground-stacked arrays. The software takes into consideration several variables that can affect the stability of an array, including outside factors such as someone pushing on an array. Based on this data, LAC-3 generates a safety assessment factor and notifies the user of potential mechanical or stability problems. Errors and warnings generated fall into one of the following categories:

#### No errors or messages

In this case, the array is stable under normal conditions and can be used as is. The array also complies with the mechanical limits set by JBL for the speakers and selected accessories.

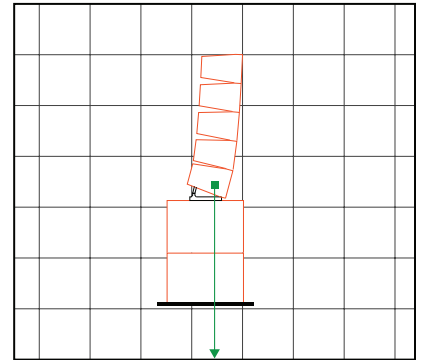

#### WARNING: Stability Hazard! - Stack Could Become Unstable - Secure to Ground

This message is an alert that the array is potentially unstable and a tipping hazard condition has been detected. The user is responsible for securing the array to the ground, stage, or other structure that can provide additional support and is rated for the weight of the array. This message may also be warning of external factors that can influence stability, such as someone accidentally pushing the array.

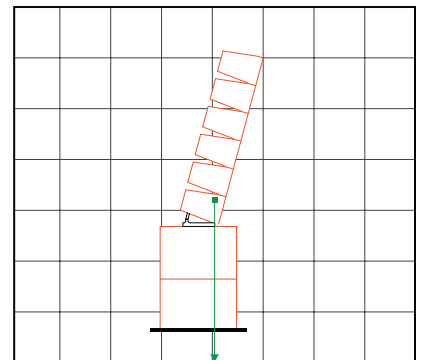

#### Configuration exceeds the maximum number of boxes allowed

This message is presented when the specified array design exceeds the mechanical limits set by the JBL team for the speakers or selected accessories. Array designs that trigger this message should not be used under any conditions, as they can lead to hardware damage and/or injury.

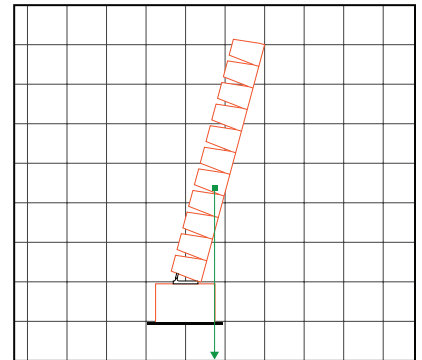

#### Invalid CG Location

This message is presented when the Center of Gravity of an array design exceeds the footprint of the selected accessory. Array designs that trigger this message should not be used under any conditions, as they can lead to hardware damage and/or injury.

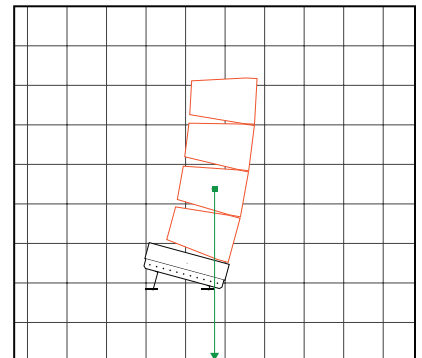

● Center of Gravity

## 5 - RIGGING SYSTEM

The B28 uses a simple two-point rigging system capable of suspending arrays of up to 16 B28 enclosures. Rigging components are hidden behind the wooden side panels, and the link bars are deployed by a spring-loaded mechanism. A unique, all-captive locking system secures cabinets together using a set of levers and sliding pins. The mechanism includes a safety lock to prevent unintentional release, and complies with all safety requirements. When B28 cabinets are ground stacked, the all-captive design keeps unused parts hidden and damped from rattling. The B28 rigging system and enclosure is front-to-back symmetric, ideal for creating flown or ground-stacked arrays, in omnidirectional or cardioid configurations.

### 5.1 OVERVIEW

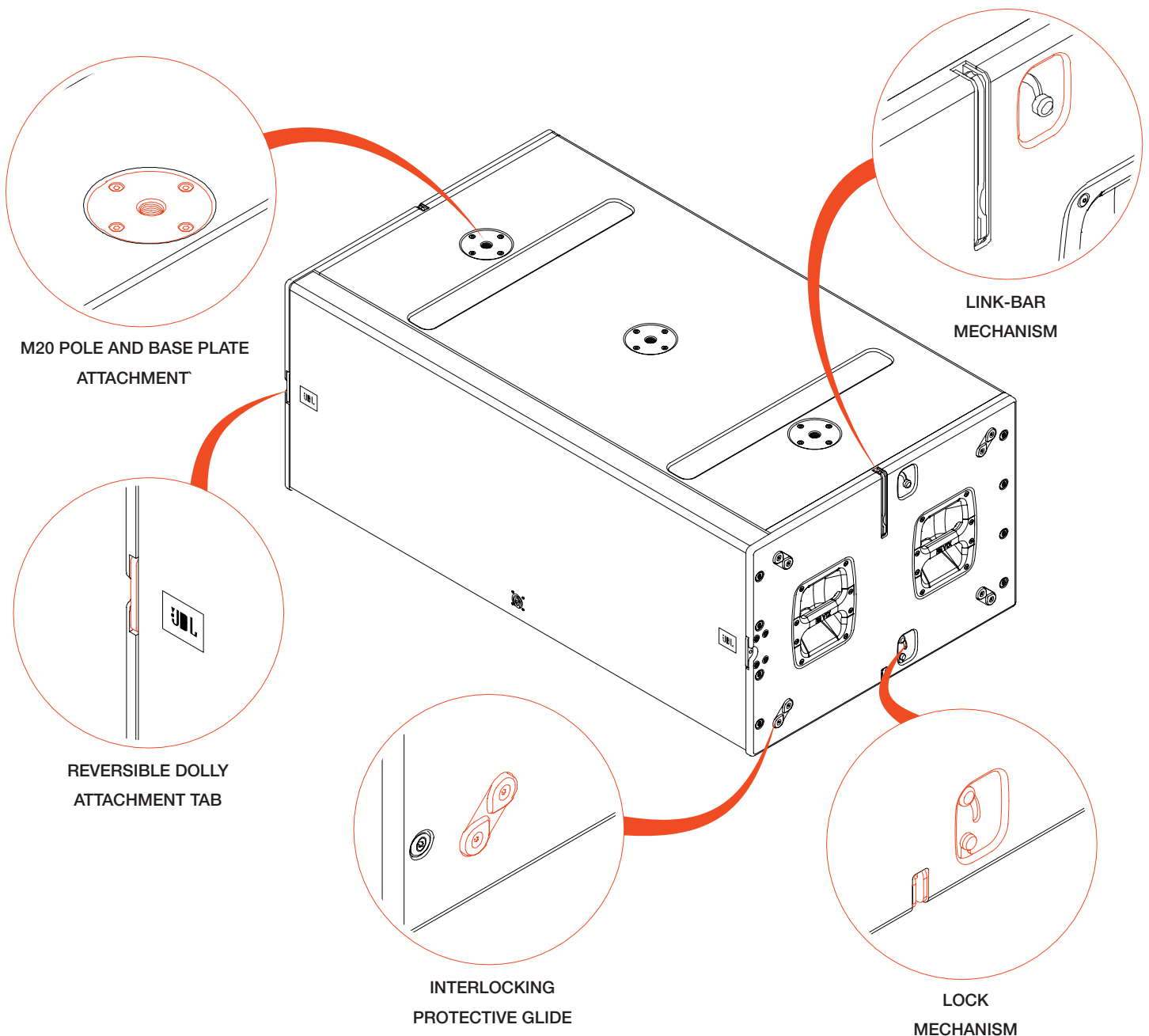

### 5.2 THE RIGGING MECHANISM

The B28 rigging system consists of two main mechanisms, one at the top **A** and one at the bottom of the enclosure **B**. The mechanism at the top extends the link bar for connection to another cabinet. The lower mechanism locks B28 subwoofers together.

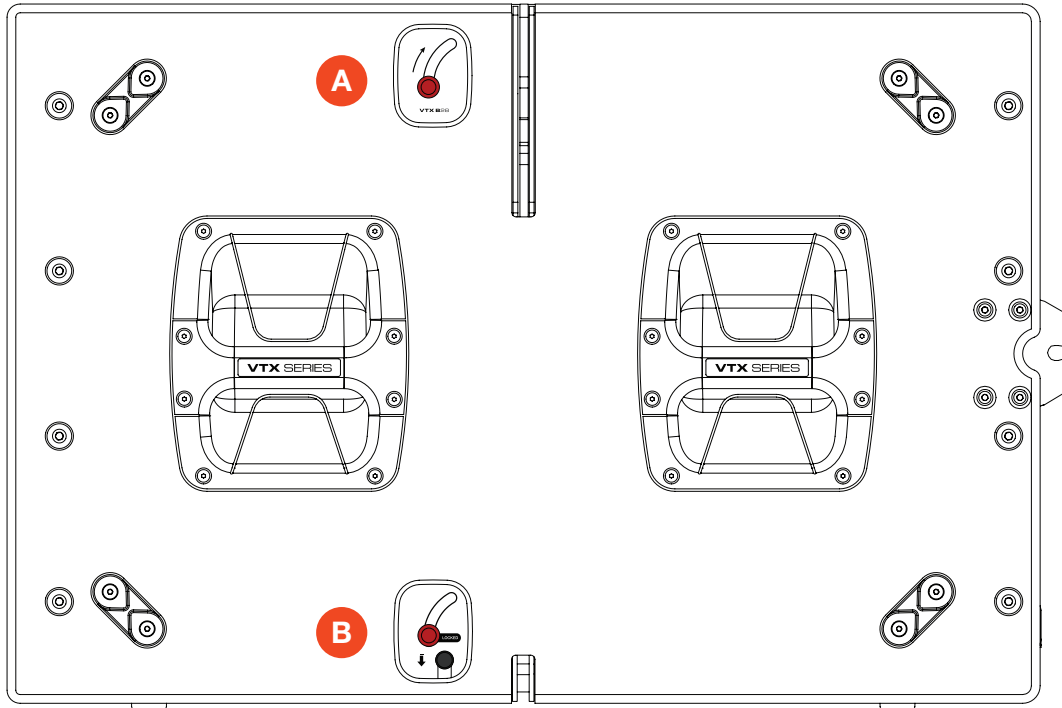

- A** The top mechanism is spring-loaded; the RED lever releases the link bar. To extend the link bar, move the RED lever up until the mechanism releases. Once extended, the link bar remains in the extended position until the user manually retracts it for storage or transportation. To retract the link bar, simply press the top of the bar down until the RED lever moves back to the lower position and a “clack” sound is heard. Note that the RED lever is used only to extend the bar, not to retract it.

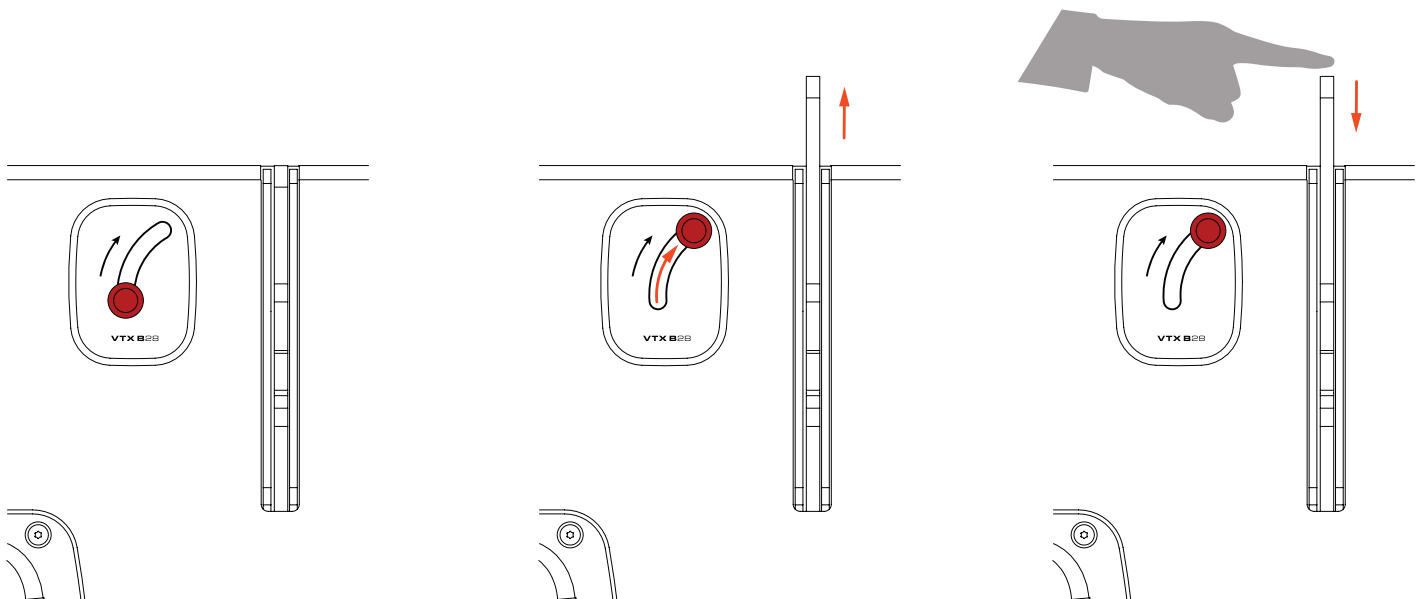

When cabinets are stacked together, the top of the link bar is not accessible. In this situation, the bar is lowered using a finger notch on the side of the cabinet.

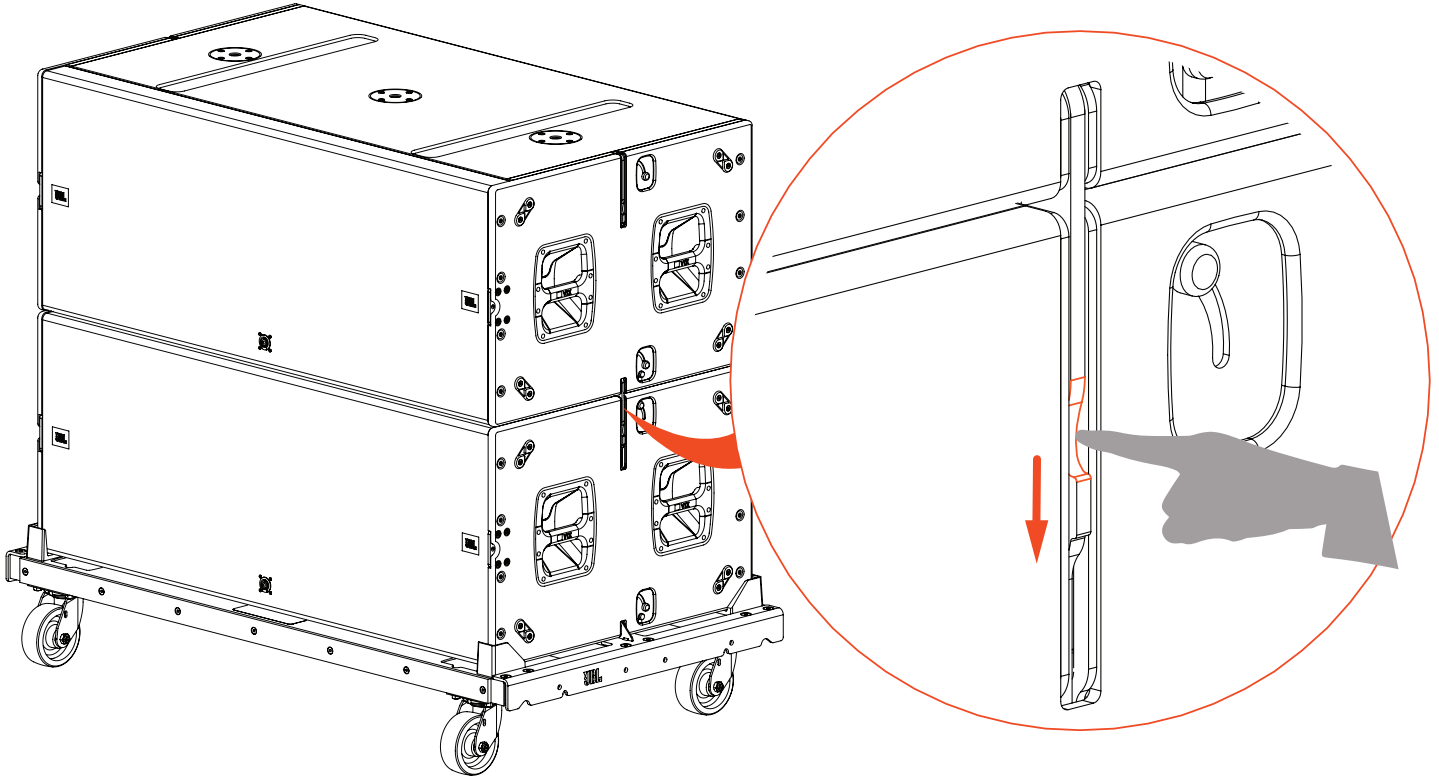

**B** The lower mechanism secures B28 cabinets together. The mechanism is controlled by the RED lever, which moves a pin through the link bar of the cabinet below. A safety button prevents unintentional disengagement of the pin. The default position is down (locked). To retract the pin, first press down the safety button, then push the RED lever up. The lock is then disengaged, and the cabinet ready to connect to another B28. Move the lever back to the lower position to close the lock.

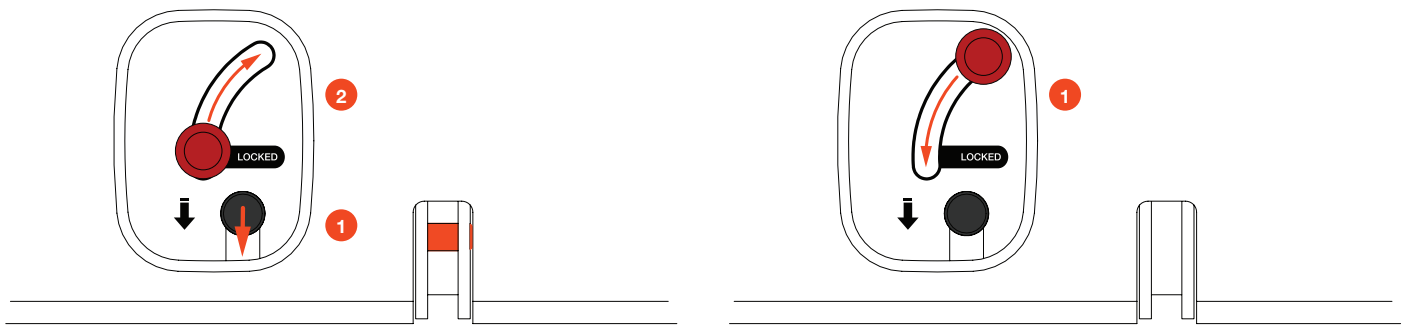

**TO UNLOCK:**

- 1 Press and hold down the BLACK button.
- 2 Move the RED lever up.

**TO LOCK:**

- 1 Move the RED lever down.



### 5.3 CONNECTING CABINETS TOGETHER

**STEPS:**

- 1 Stack the cabinets.
- 2 Open the LOCK of the top B28.
- 3 Extend the link bar.
- 4 Close the lock.

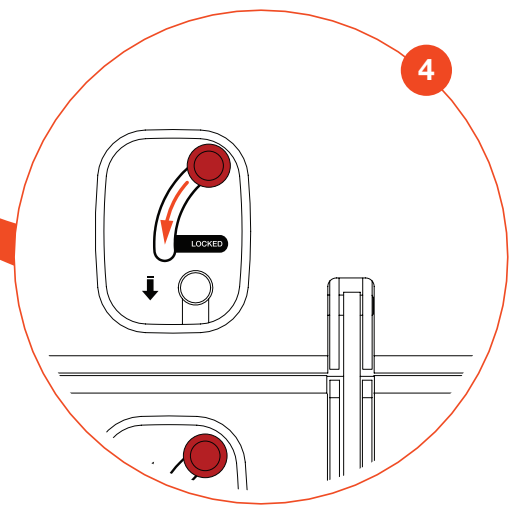
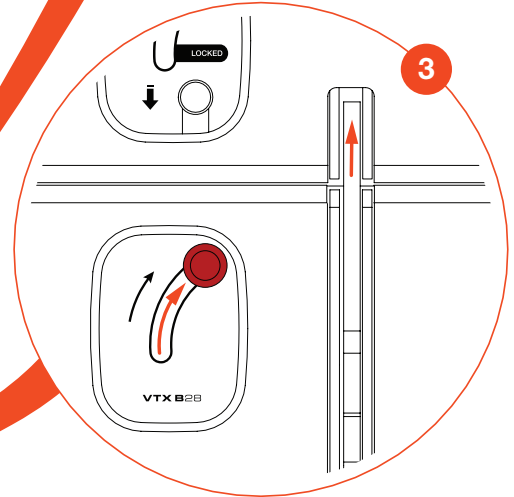
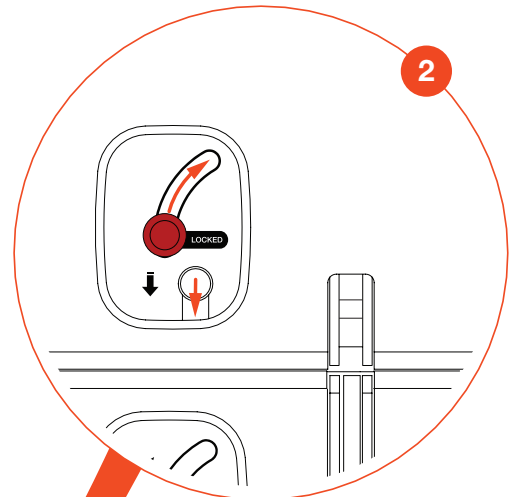
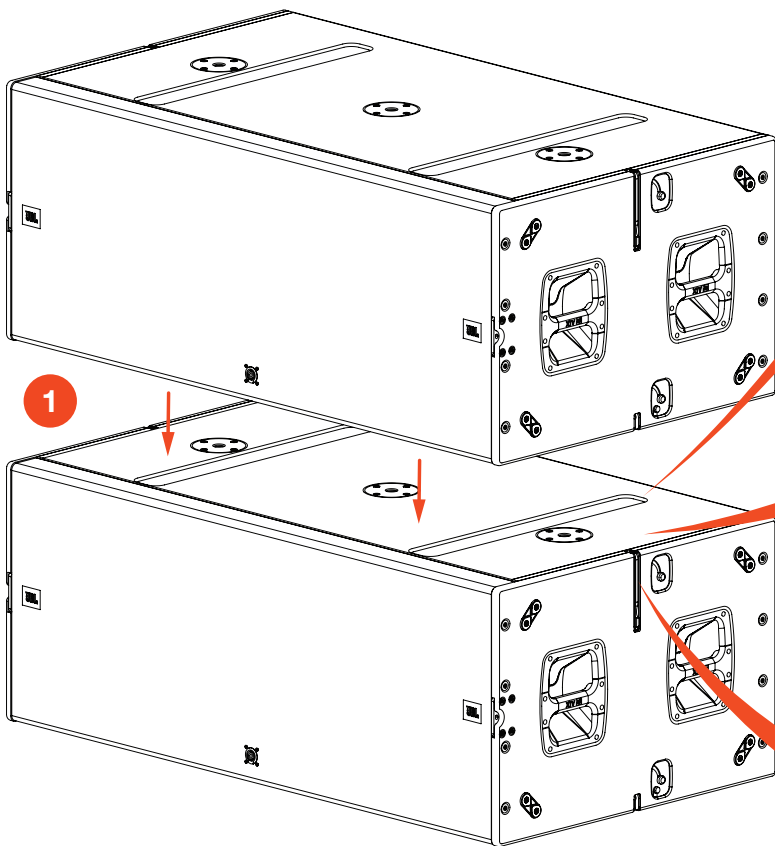

**CAUTION:** Always ensure that locks are fully seated and that both sides of the B28 rigging are deployed and engaged before lifting.

**5.4 LOCKED AND UNLOCKED EXAMPLE**

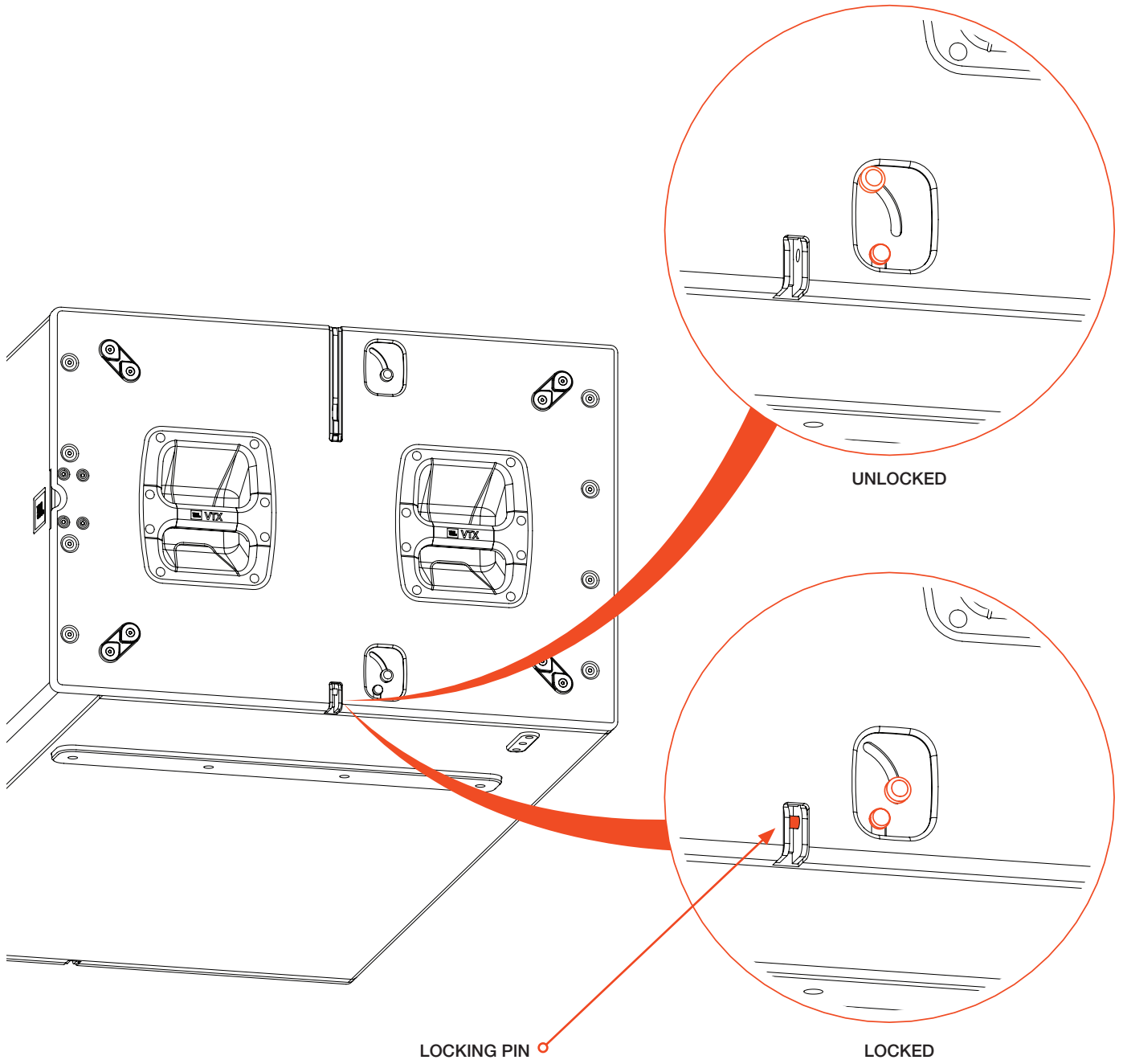

## 6 - TRANSPORTATION OPTIONS

B28 subwoofers can be transported singly or in stacks. The VTX B28 VT Vertical Transporter cart allows transporting stacks of up to four B28 subwoofers. When stacked in blocks of two, three, or four, B28 cabinets can be transported in either front-firing or cardioid configurations. The VTX B28 VT CVR, a reinforced cover, is available for protecting subwoofers during transportation. The VT option is ideal for large-scale touring situations where large format trucks are used and maximum deployment efficiency is needed. Single B28 cabinets can be transported using the VTX B28 ACC accessory kit, which includes a front-face dolly and a protective cover. The ACC option is more agile and efficient for transportation, as it allows stacking B28 subwoofers on top of other equipment in the trucks.

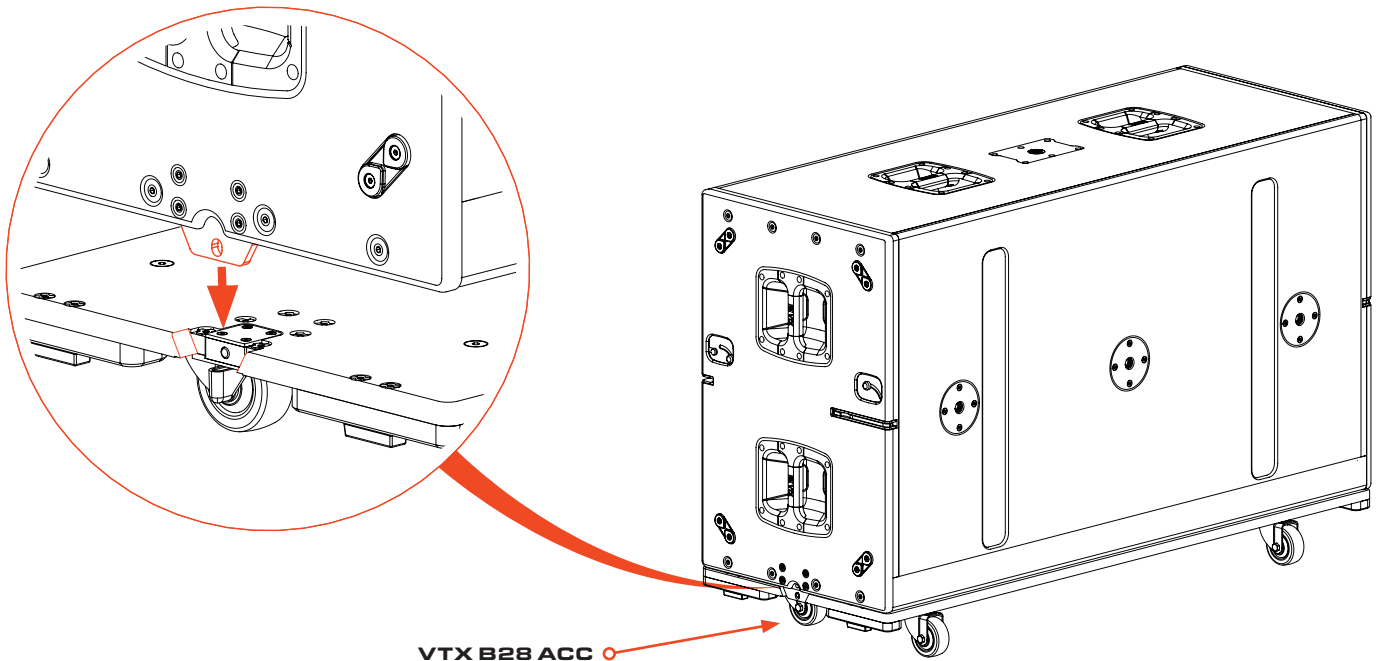
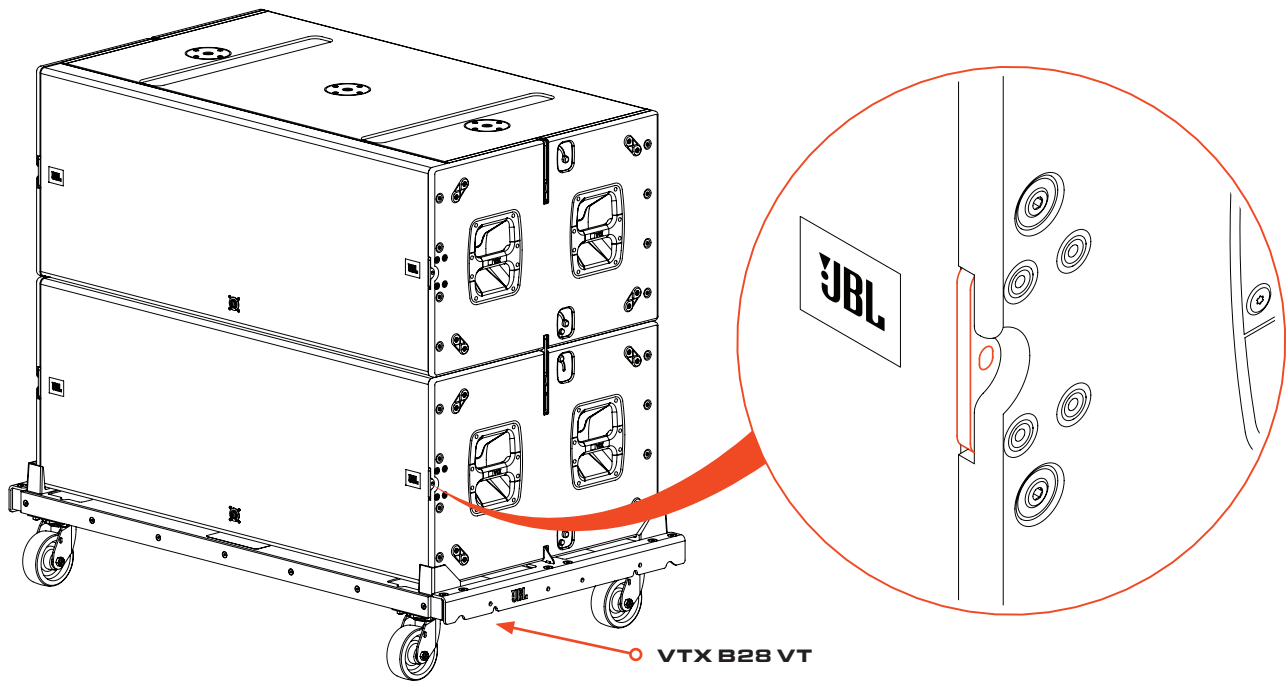

## 6.1 ROTATING THE DOLLY TABS FOR USE WITH THE ACC DOLLY

Two dolly tabs at the front of the B28 are used to secure the front-face ACC dolly board to the B28. The tabs are retractable and ship from the factory in the retracted position inside the B28. This orientation is ideal when B28s are on a vertical transport cart, where the tabs are not needed, but the tabs must be rotated to attach a front-face dolly board to the B28.

### STEPS:

- 1 Remove the four M6 HEX bolts holding the bracket onto the B28.
- 2 Rotate the bracket to the extended position.
- 3 Install the bolts.
- 4 Repeat for the other side.

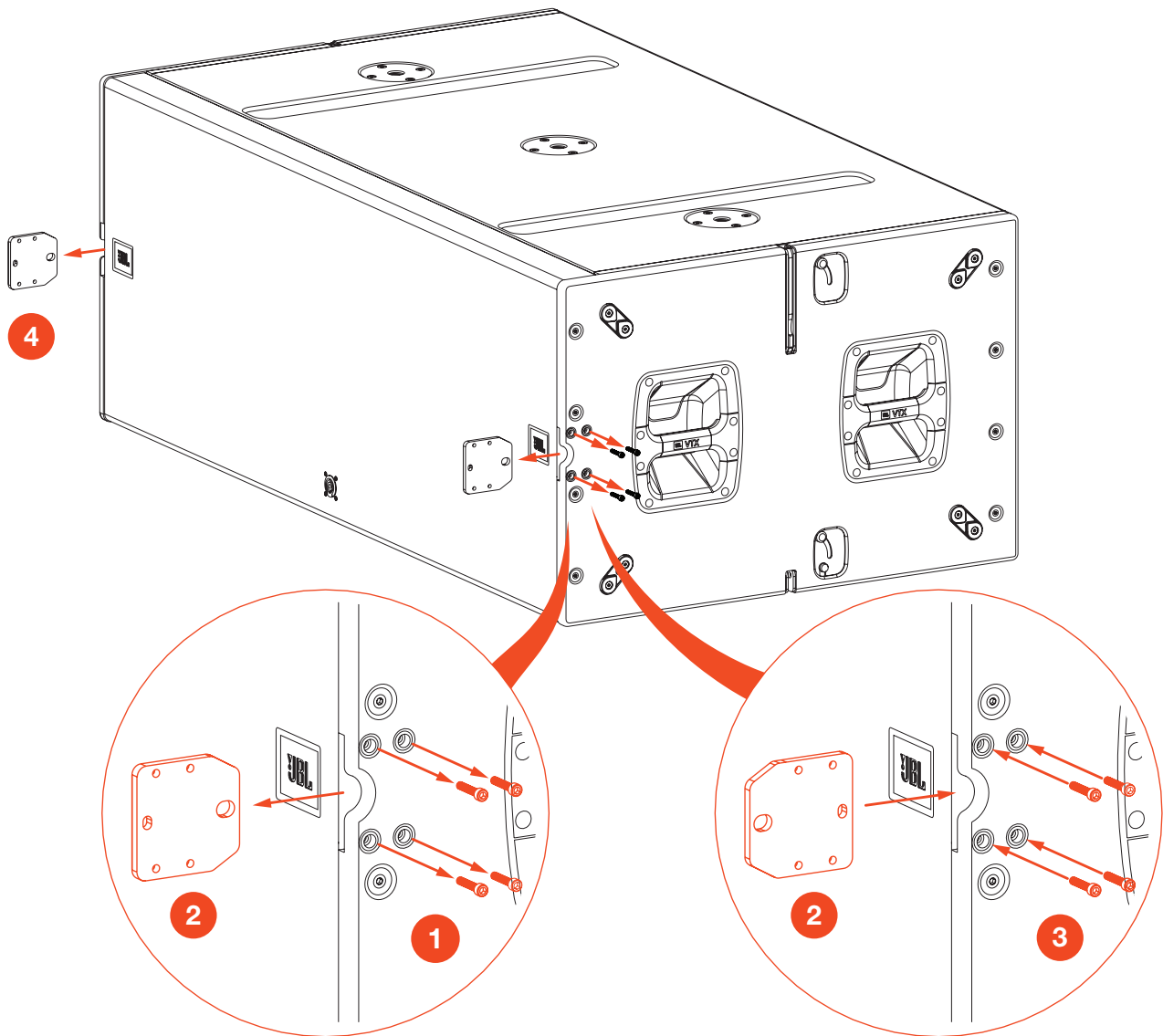

**TOOLS REQUIRED:** A Torx T25 wrench is required to remove the four bolts holding the ACC brackets. All bolts should be torqued to 2.82 N.m (25 in.lbs).

## 7 - VTX B28 ACC DOLLY OVERVIEW

The VTX B28 ACC dolly board features two beveled, recessed, rotating cams (one on each side), which are used to attach the dolly board to a B28 cabinet. The dolly board self-seats onto the B28 mounting tabs, and the rotating cams secure the dolly onto the B28.

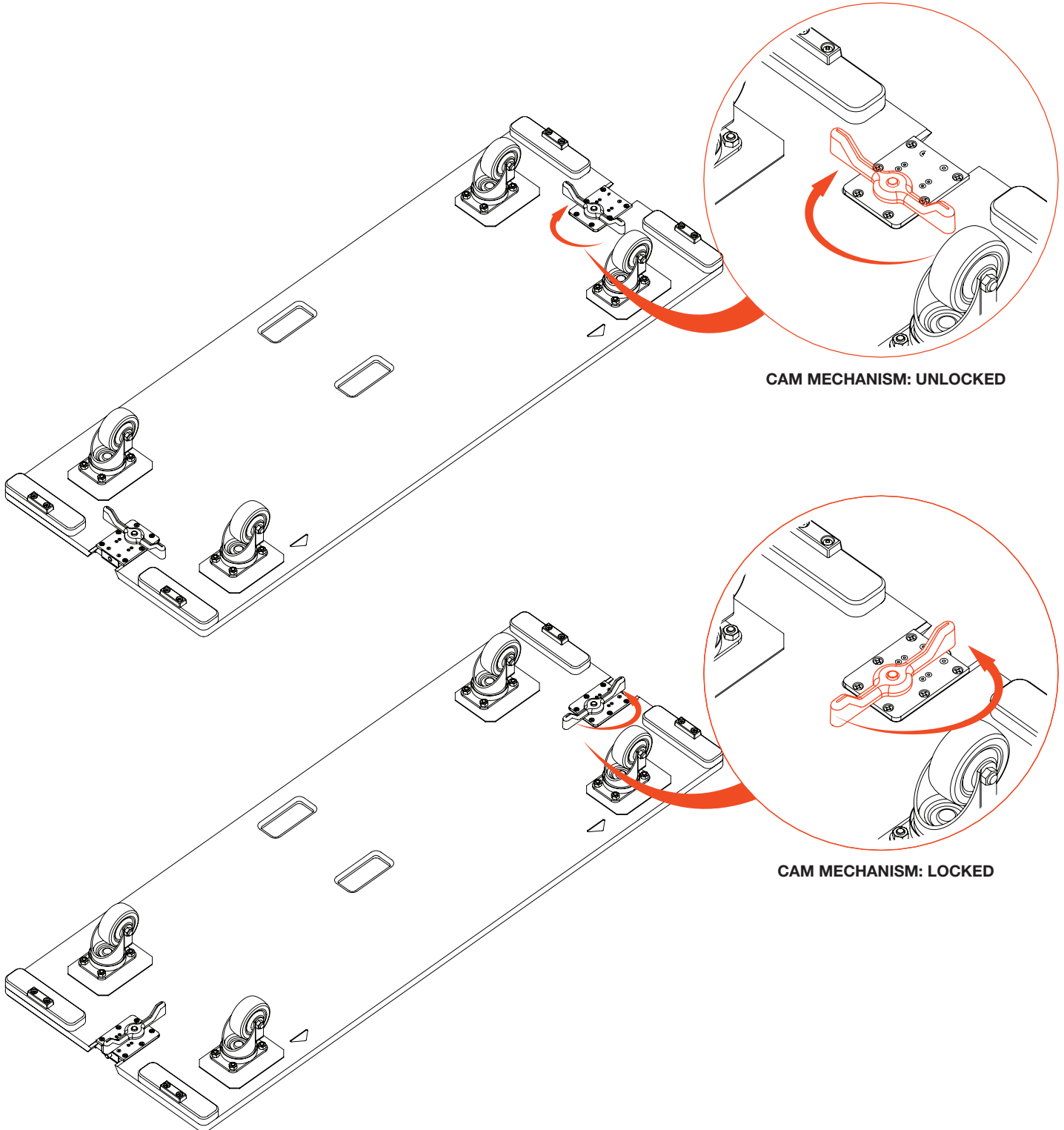

CAM MECHANISM: UNLOCKED

CAM MECHANISM: LOCKED



**TIP:** The rotating cam mechanism can be released using your feet while B18 cabinets are face down.

**7.1 ATTACHING THE VTX B28 ACC DOLLY**

**STEPS:**

- 1 Flip one of the two cam mechanisms to the locked position.
- 2 Slide the ACC dolly board onto the B28 from either side.
- 3 Lock the other cam mechanism to secure the ACC onto the B28.

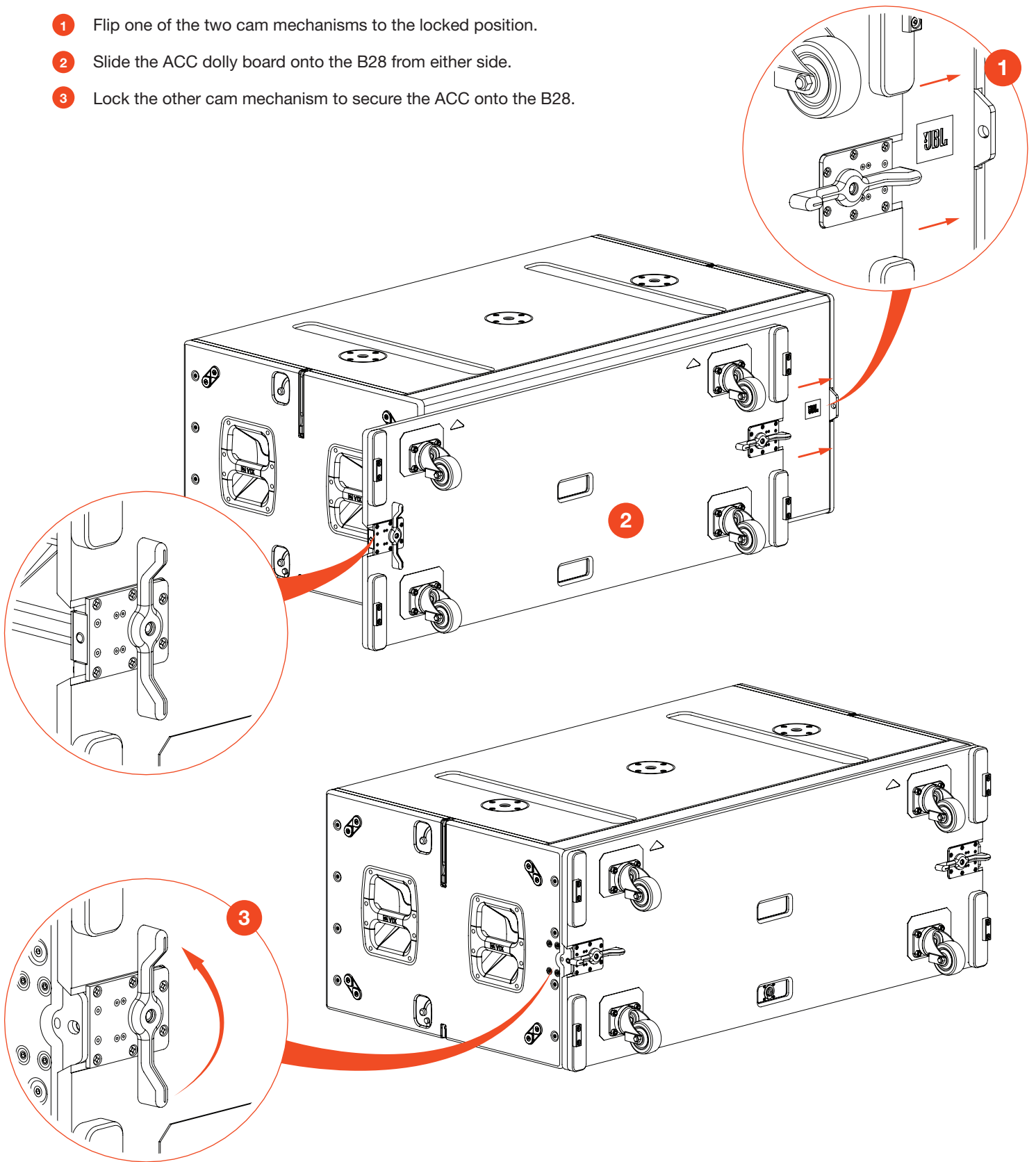

## 7.2 STACKING THE ACC DOLLY BOARDS

VTX B28 ACC dollies can be stacked together for storage. The dolly's handles and wheel wells were designed to allow stacking without having to touch or manually turn the wheels. When the ACC is held by the handle near its edge, gravity orients the wheels downward. Alignment arrows are located near one edge on both the top and bottom of the ACC to identify the correct orientation. To stack two ACCs, line up the arrows on the bottom of the ACC being added to the stack with the arrows on the top ACC on the stack, then lower the ACC onto the stack.

### STEPS:

- 1 Place the first ACC dolly on the ground.
- 2 Hold the next dolly by the handle located close to the edge so that it is vertical. All four wheels will be oriented downwards.
- 3 Using the arrows for orientation, fit the lower wheels into the nearest wheel wells of the ACC on the ground.
- 4 Once the lower wheels are aligned, lay the dolly flat, seating the upper wheels into the remaining wheel wells.
- 5 Repeat the process as needed to stack all ACC dolly boards.

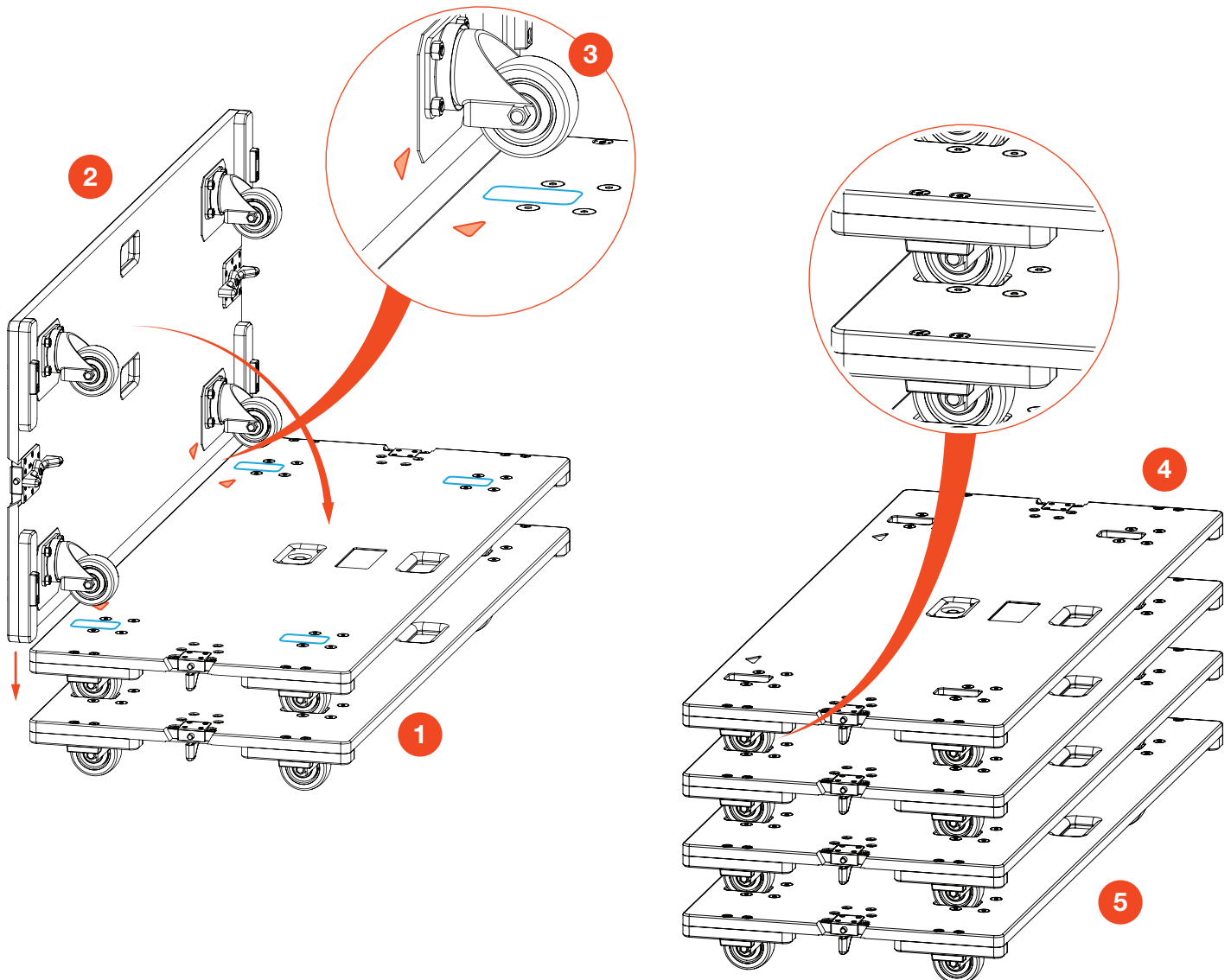

### 7.3 TRUCK PACKING WITH ACC

**OPTION 1:** On end, four across.

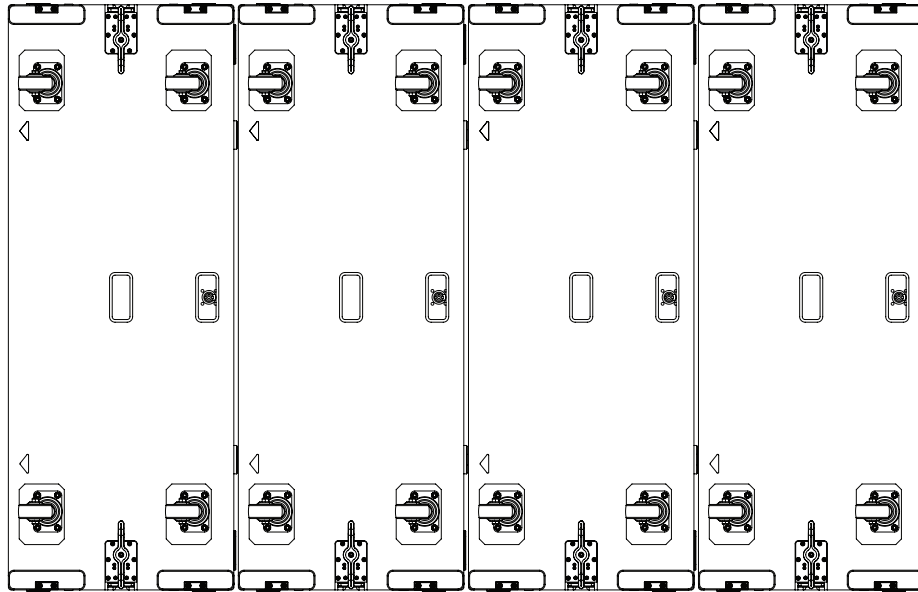

**OPTION 2:** On wheels, four across, stacked two high.

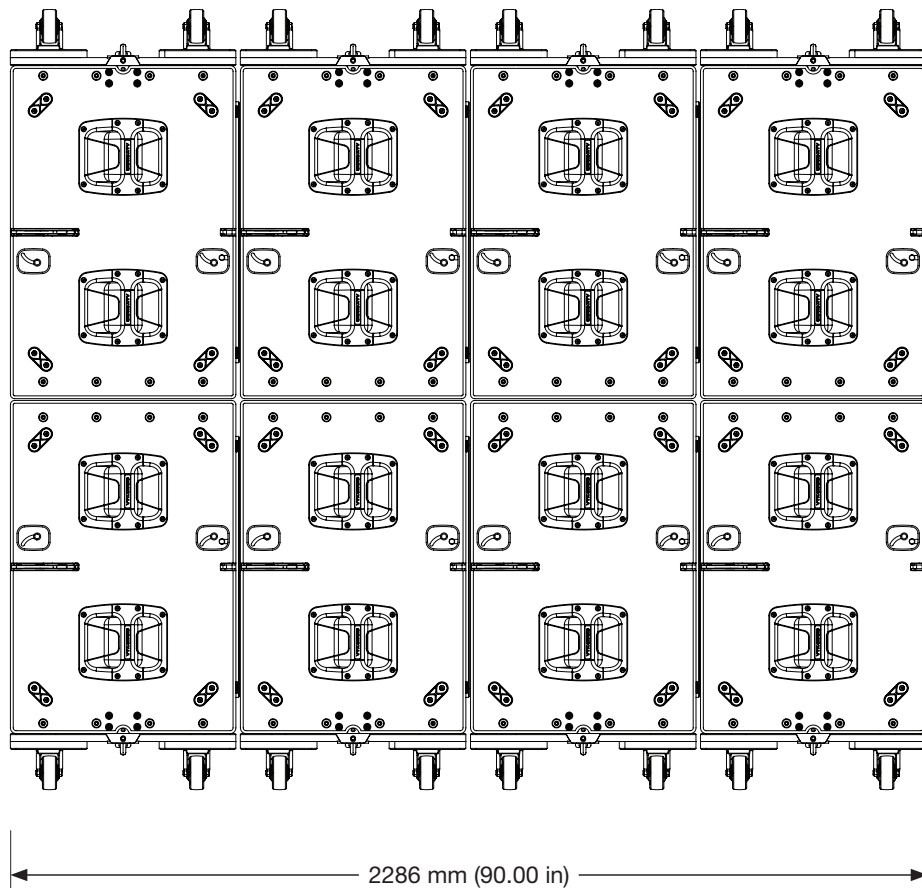



## 8 - THE VERTICAL TRANSPORTER

The VTX B28 VT Vertical Transporter is a robust, lightweight cart solution for vertically transporting up to four VTX B28 enclosures. The VTX B28 VT is constructed of aluminum and steel parts and measures 57 inches (1448 mm) wide and 32 inches (813 mm) deep. Stacks of two, three, or four B28 cabinets can be transported while stacked in either front-firing or cardioid configurations. The VTX B28 VT CVR, a reinforced protective cover, is available separately. The B28 VT includes mounting holes on each side for attaching to the VTX A12 VT GND outrigger system. The GND attachment provides additional stability for taller B28 ground-stacked arrays or in mixed ground stack configurations containing B28s and supported VTX full-range cabinets.

### 8.1 - VTX B28 VT OVERVIEW

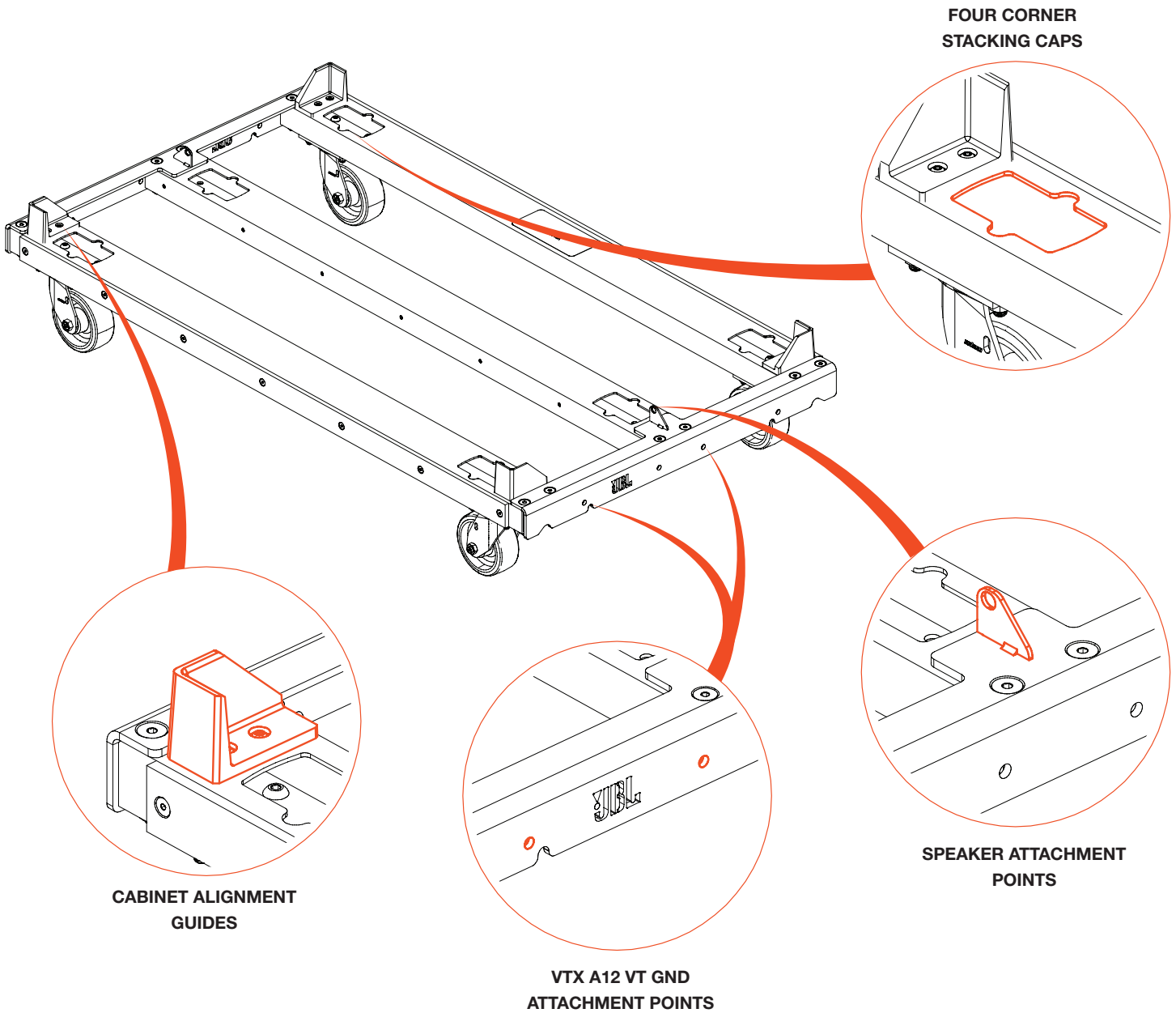

FOUR CORNER STACKING CAPS

CABINET ALIGNMENT GUIDES

VTX A12 VT GND ATTACHMENT POINTS

SPEAKER ATTACHMENT POINTS



**CAUTION:** No more than four VTX B28 cabinets should be transported on a single VTX B28 VT. However, the VT is capable of bearing a static load of up to 16 B28 cabinets during rigging.

**8.2 INSTALLING VTX B28 CABINETS ON THE VT**

The VT includes corner guides that align and center the cabinet on the cart. This makes it very easy to land a B28 array on a VT without guesswork or needing to relocate the cabinets once landed. The B28 rigging lock secures the B28 subwoofers onto the VT. When attaching to flown arrays, it is recommended that subwoofers be lowered onto the VT, rather than lifting the VT to the flown array.

**STEPS:**

- 1 Open the LOCK.
- 2 Using the four corner guides for alignment, lower the B28 onto the VT cart.
- 3 Close the LOCK.

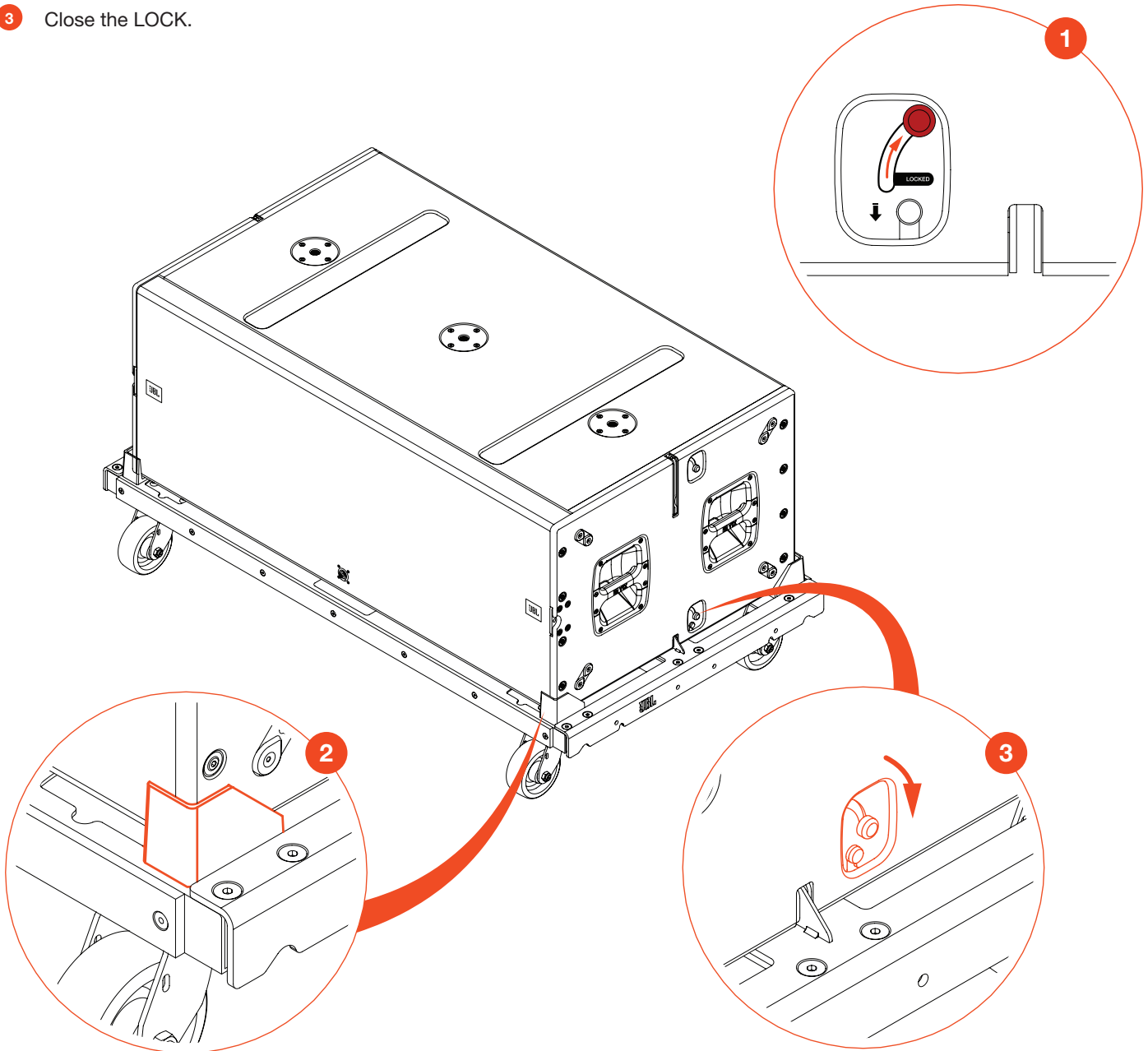

**CAUTION:** Make sure that the B28 lock is open before lowering a B28 array onto the VT. B28 stacks should never be shipped on a VT in the unlocked position. This can risk damage to the B28 rigging or the VT, or cause personal injury.

### 8.3 VTX B28 VT CVR

The VTX B28 VT CVR is a heavy-duty soft cover designed to work with the VTX B28 VT Vertical Transporter. The B28 VT CVR is sized to cover three or four VTX B28 enclosures and features two industrial-rated zippers for easy and reliable deployment. The cover includes input-panel flaps, allowing VTX B28 enclosures to be tested without having to remove the cover. Handle cutouts are provided for easy manipulation, and the front section panels are internally reinforced for maximum protection of the speaker grilles. The VTX B28 VT CVR folds into a compact footprint when not in use. Weight: 15.4 kg (34 lbs).

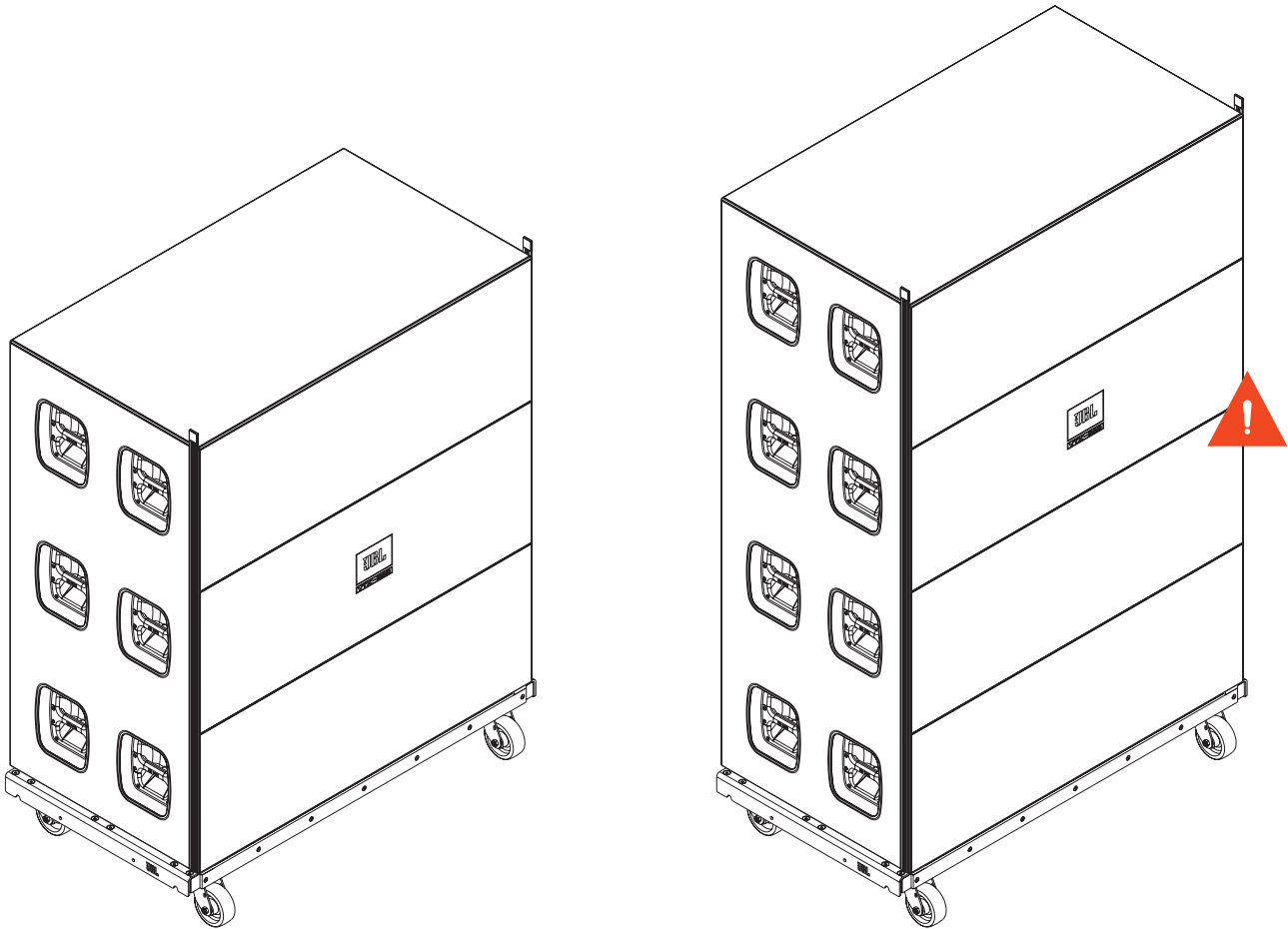

**CAUTION:** Stacks of four B28 cabinets on a vertical transporter comes to 2.2 meters (89.1 in) high, which might be taller than some noncommercial doors. Use caution when pushing stacks through hallways and doors. Use stacks of three to ensure fit in all situations.

### 8.4 STACKING THE VTX B28 VT

VTX B28 VT carts can be stacked for storage.

**STEPS:**

- 1 Rotate the VT wheels inward to point towards the opposite end of the cart.
- 2 Line up the wheels to seat into the wheel wells of the VT below it.
- 3 Stack the carts.
- 4 Repeat until all VTs are stacked.

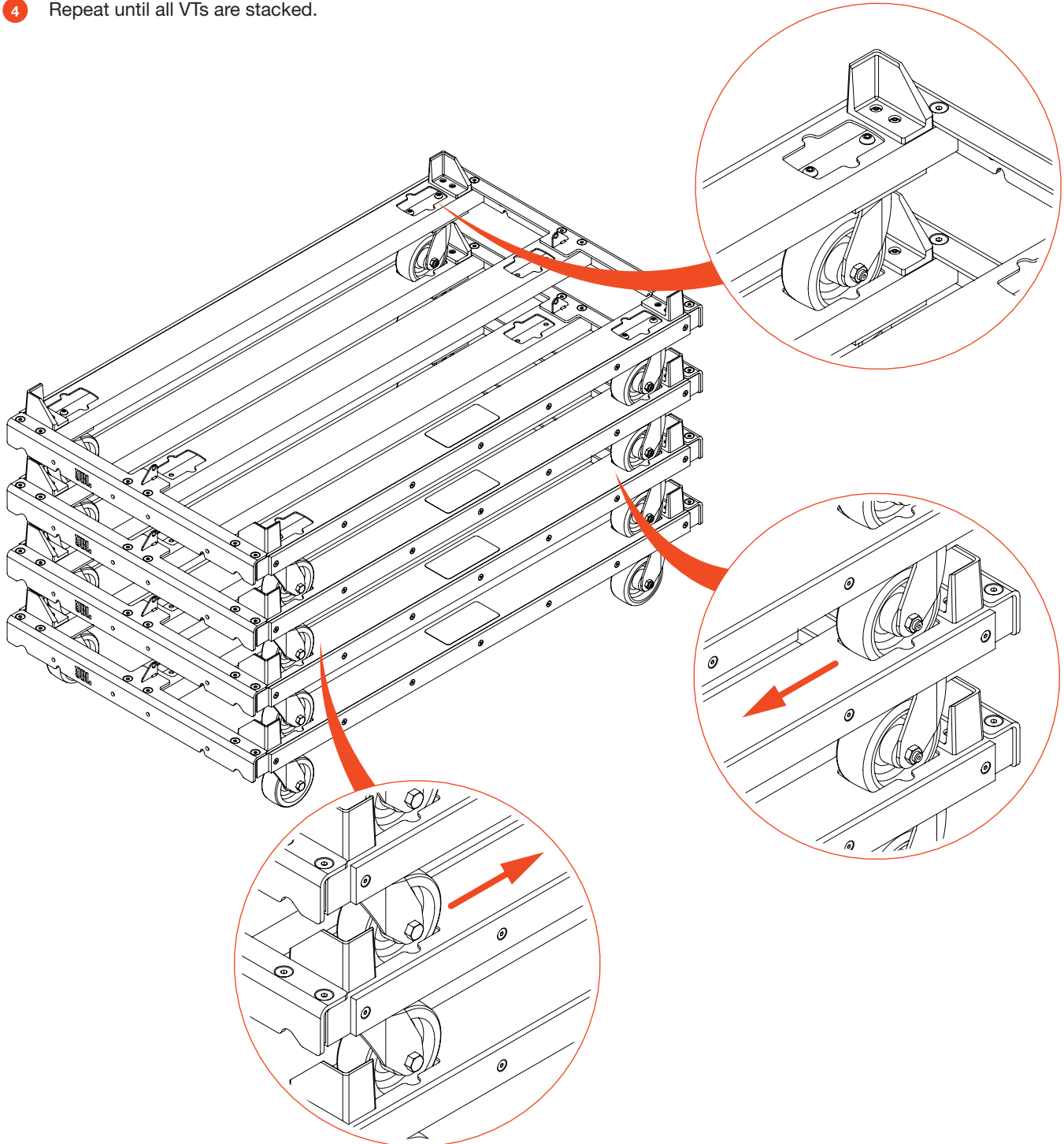

8.5 TRUCK PACKING WITH VT

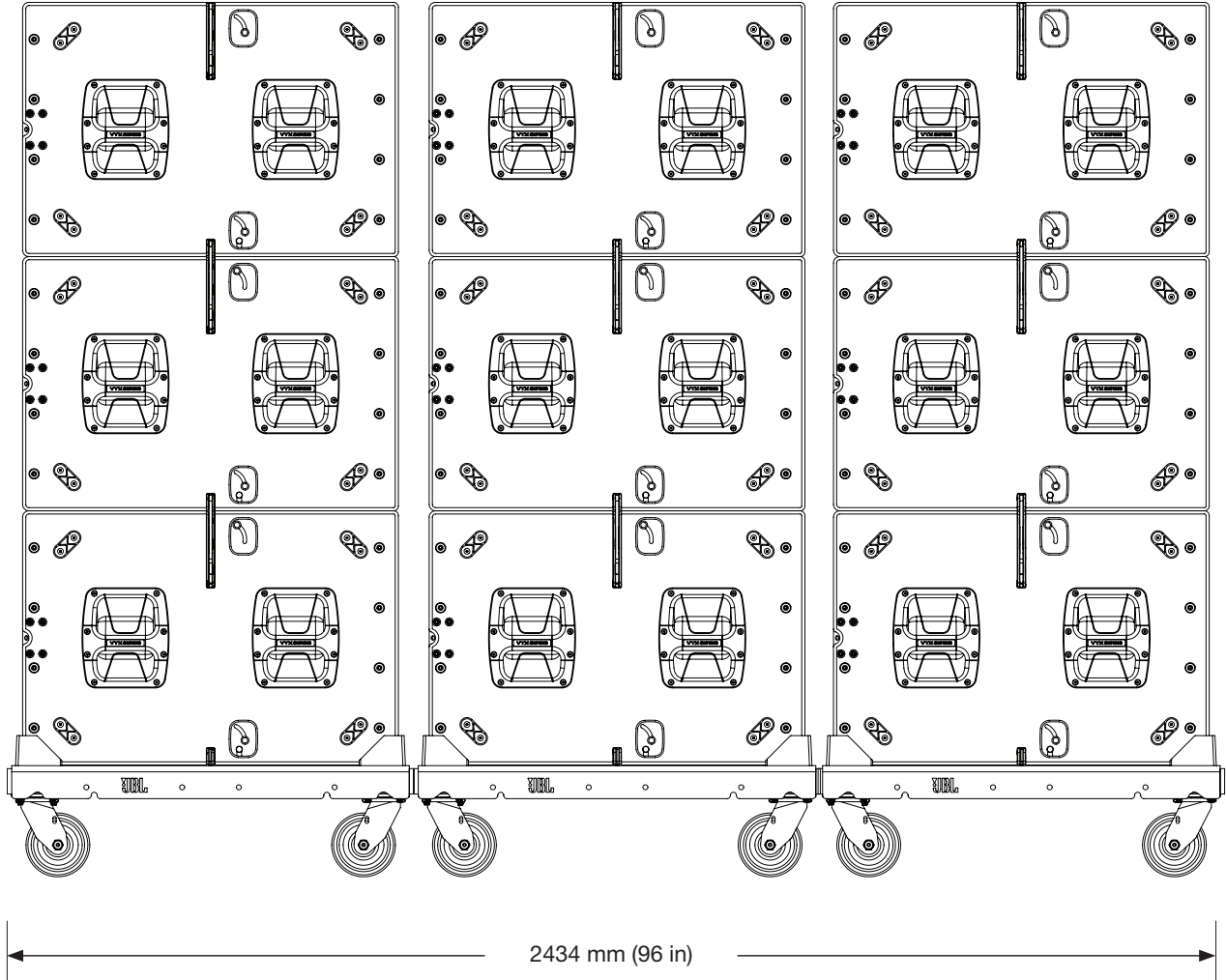

## 9 - THE VTX B28 SUSPENSION BAR

The VTX B28 SB is a lightweight suspension bar for use as an array frame when hanging VTX B28 subwoofer arrays. The suspension bar connects directly to the B28 left and right rigging bars and includes support for both single-point and dual-point configurations. Up to 16 VTX B28 cabinets can be suspended, and two 5/8-inch shackles are included. Several additional shackle point positions for secondary safety attachment cables are provided. The design is perfectly symmetrical and requires no specific orientation.

### 9.1 SUSPENSION BAR OVERVIEW

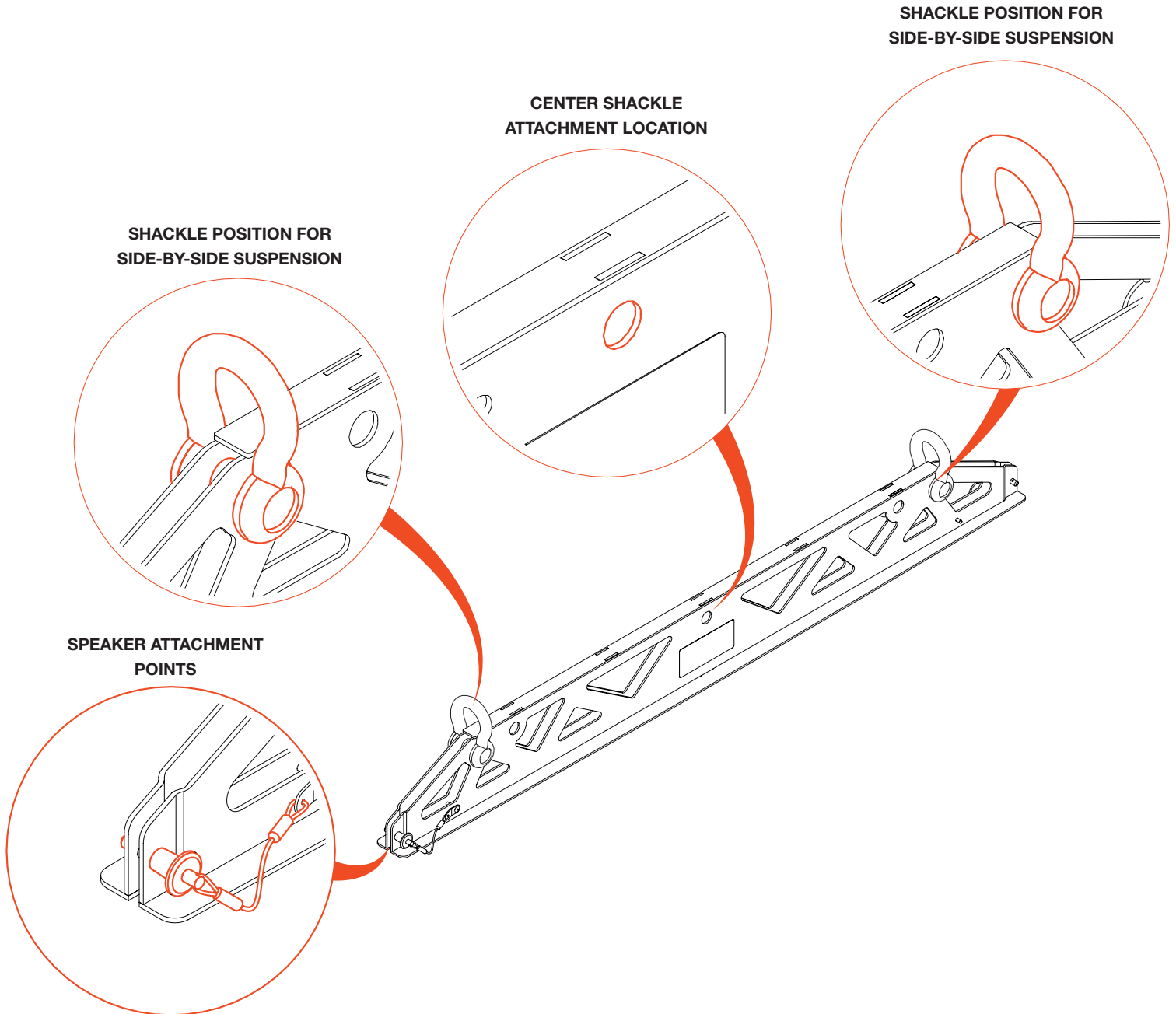

## 9.2 SUSPENDING B28 ARRAYS

Suspension of a B28 array begins with attaching the suspension bar to the first cabinet. The steps outlined over the next few pages assume the use of Vertical Transporters but similar steps are used to suspend arrays using the ACC accessory. To start the process, use the two RED levers near the top of the cabinet to extend the link bar of the first B28.

### STEPS:

- 1 Extend the B28 link bars to be connected with the suspension bar.
- 2 Lower the suspension bar onto the B28 cabinet.
- 3 Insert the quick release pins.

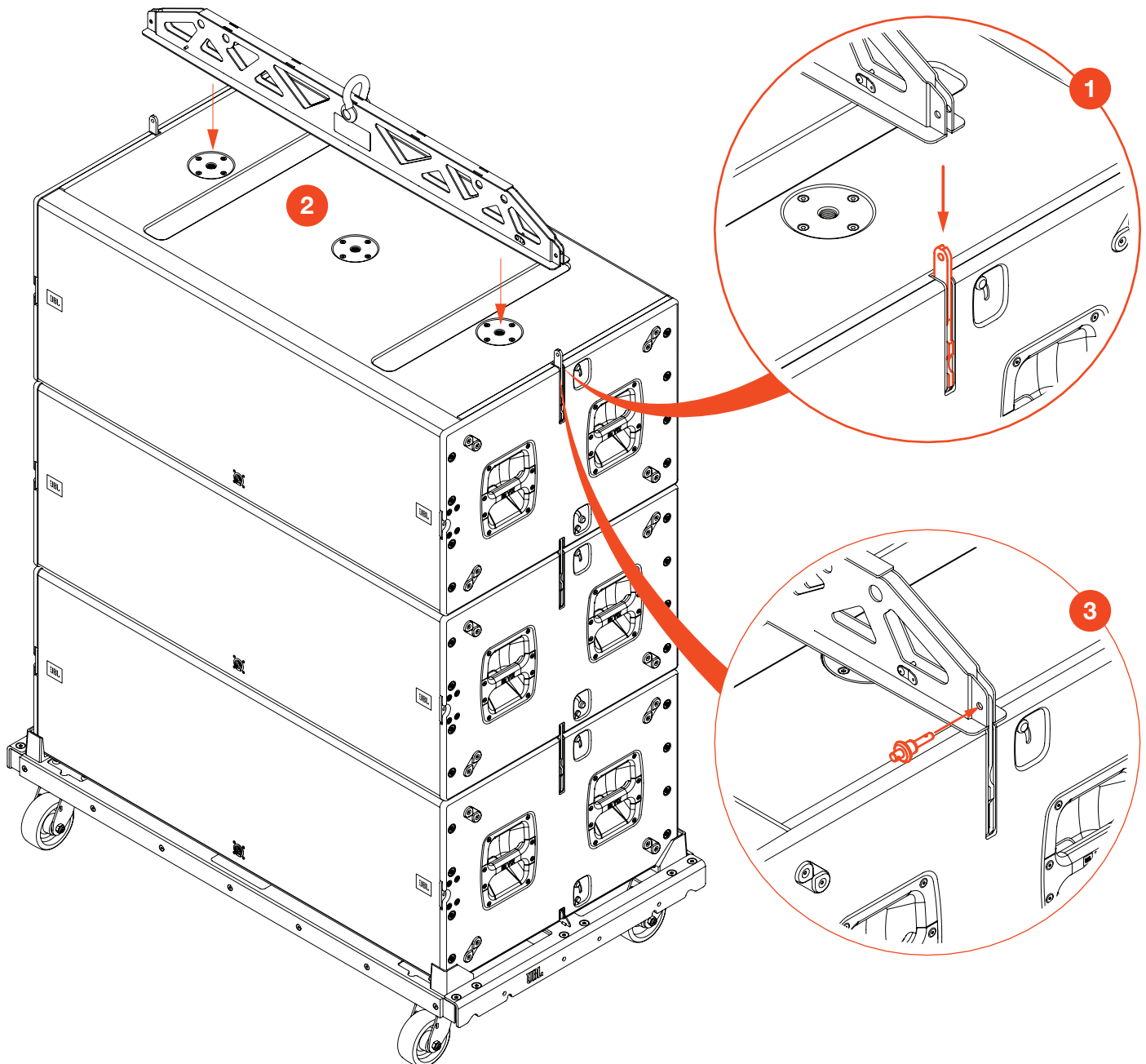

Once the suspension bar is securely attached, the array is ready for suspension. Next open the LOCK of the very last B28 to release the VT. This will allow for the VT to remain on the ground after lifting. The VT can be released after the fact but it is easier and safer to release the VT ahead of time.

### STEPS:

- 1 With the array still on the ground, open the LOCK of the last cabinet to release the VT.
- 2 Lift the array using the electric hoist to separate the array from the VT.
- 3 The VT should remain on the ground. Prepare the next stack of B28s and align it under the flown array.

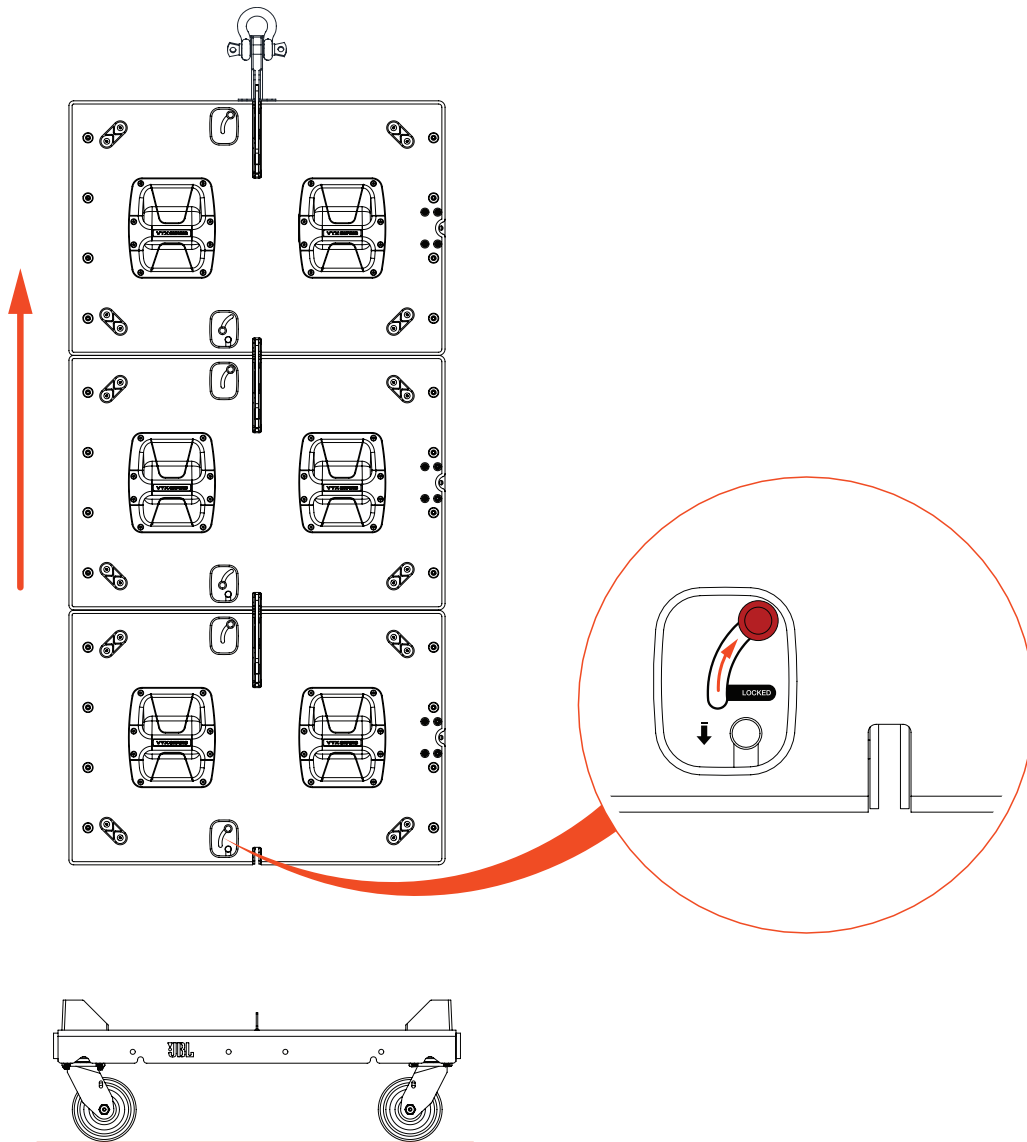

**TIP:** To release the VT after the array is lifted, use one hand to manually lift the VT to release the weight from the rigging. Use your other hand to open the B28 LOCK. The VT cannot be released when the system is under load and when the weight of the VT is resting on the rigging system. Once the LOCK is open, gently lower the VT to the ground.



The next step is to connect the flown array to additional B28 stacks on the ground. Lift the flown array high enough to allow a stack to be placed under the array. Once aligned, lower the flown array onto the stack. The two skids under the B28 will align the arrays. If the cabinets are not perfectly aligned, gently push the flown array for alignment. Once the arrays are stacked, deploy the rigging and secure the cabinets together. There is no need to deploy the link bars ahead of time.

**STEPS:**

- 1 Lower the flown array onto the next B28 stack.
- 2 Open the LOCK (if not open already).
- 3 Extend the link bar.
- 4 Close the LOCK.
- 5 Repeat the steps until the entire array is assembled.

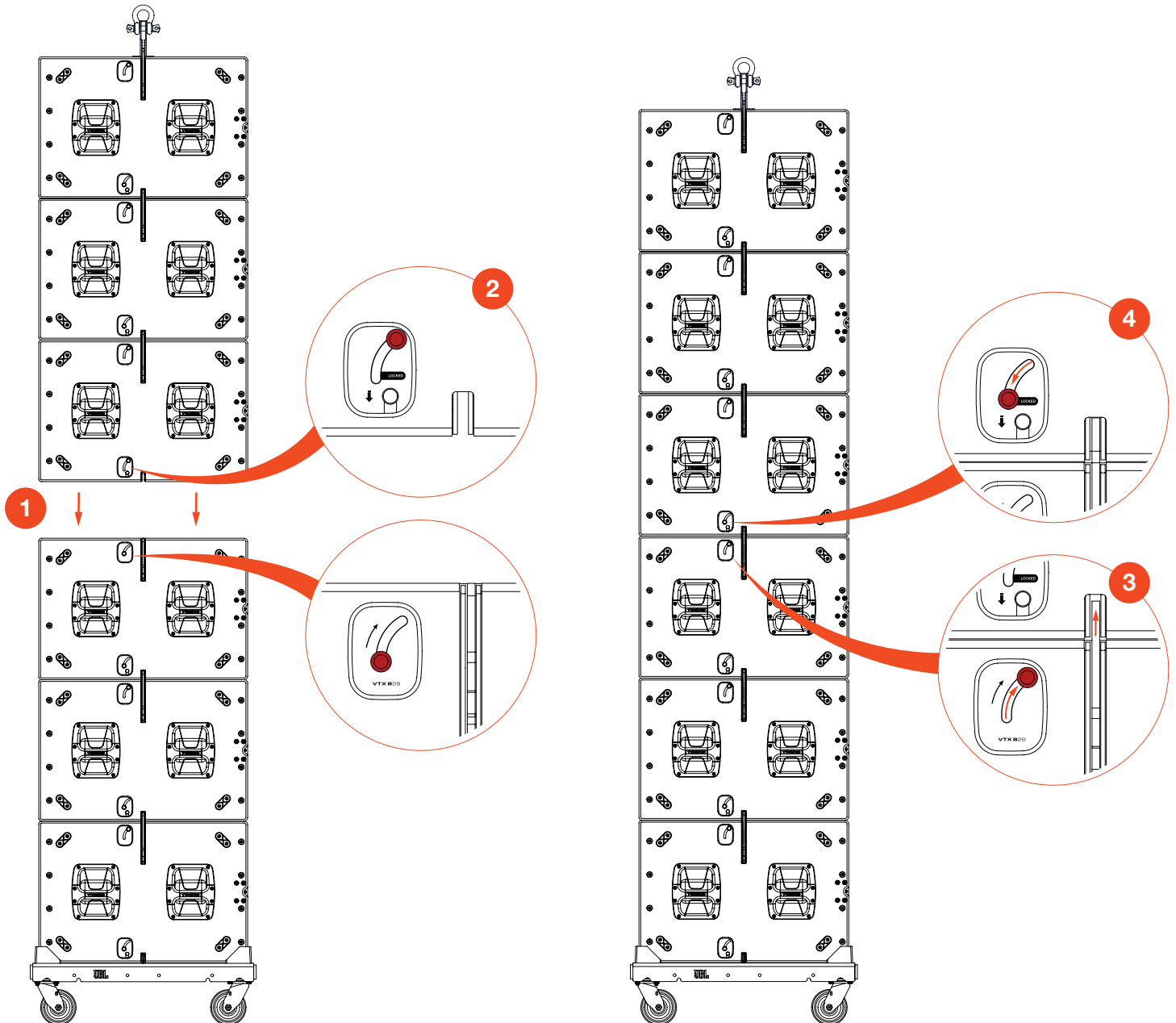

### 9.3 DISASSEMBLING ARRAYS

Disassembling B28 arrays starts by lowering the array onto the first VT. Always ensure that the LOCK of the last B28 is open before lowering the array. This enables the B28 to properly attach to the VT. Once the VT is attached, open the lock of the cabinet where you want to separate the arrays.

**STEPS:**

- 1 Open the LOCK of the bottom B28 of the array.
- 2 Lower the array onto the VT, using the corner guide to align the array with the VT.
- 3 Close the LOCK to secure the B28 array onto the VT.
- 4 Open the lock of the cabinet where you want to separate the arrays.

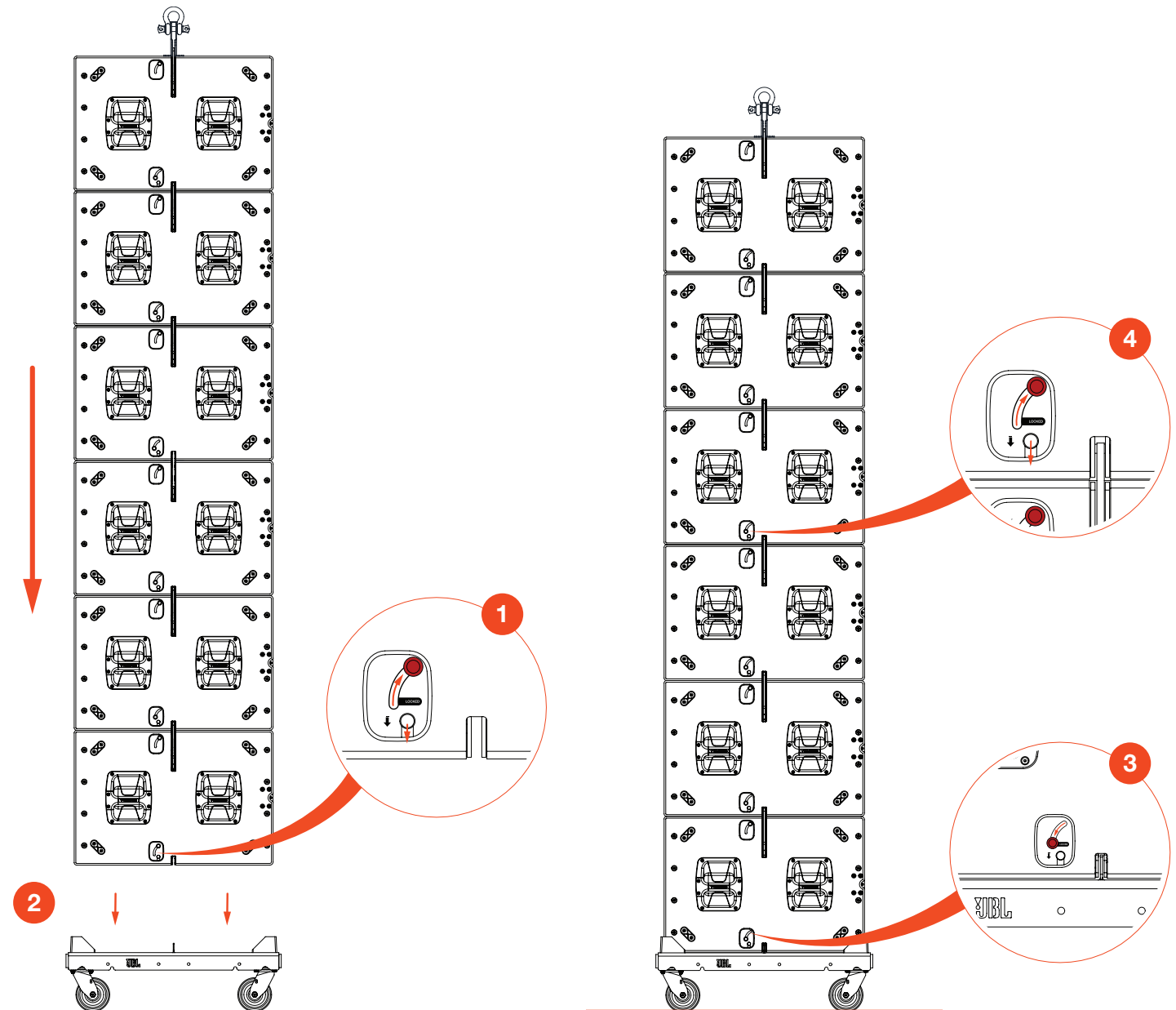

**STEPS:**

- 5 Lift to separate the arrays.
- 6 Lower the link bar to the storage position.
- 7 Repeat until array is disassembled and attached to VTs.

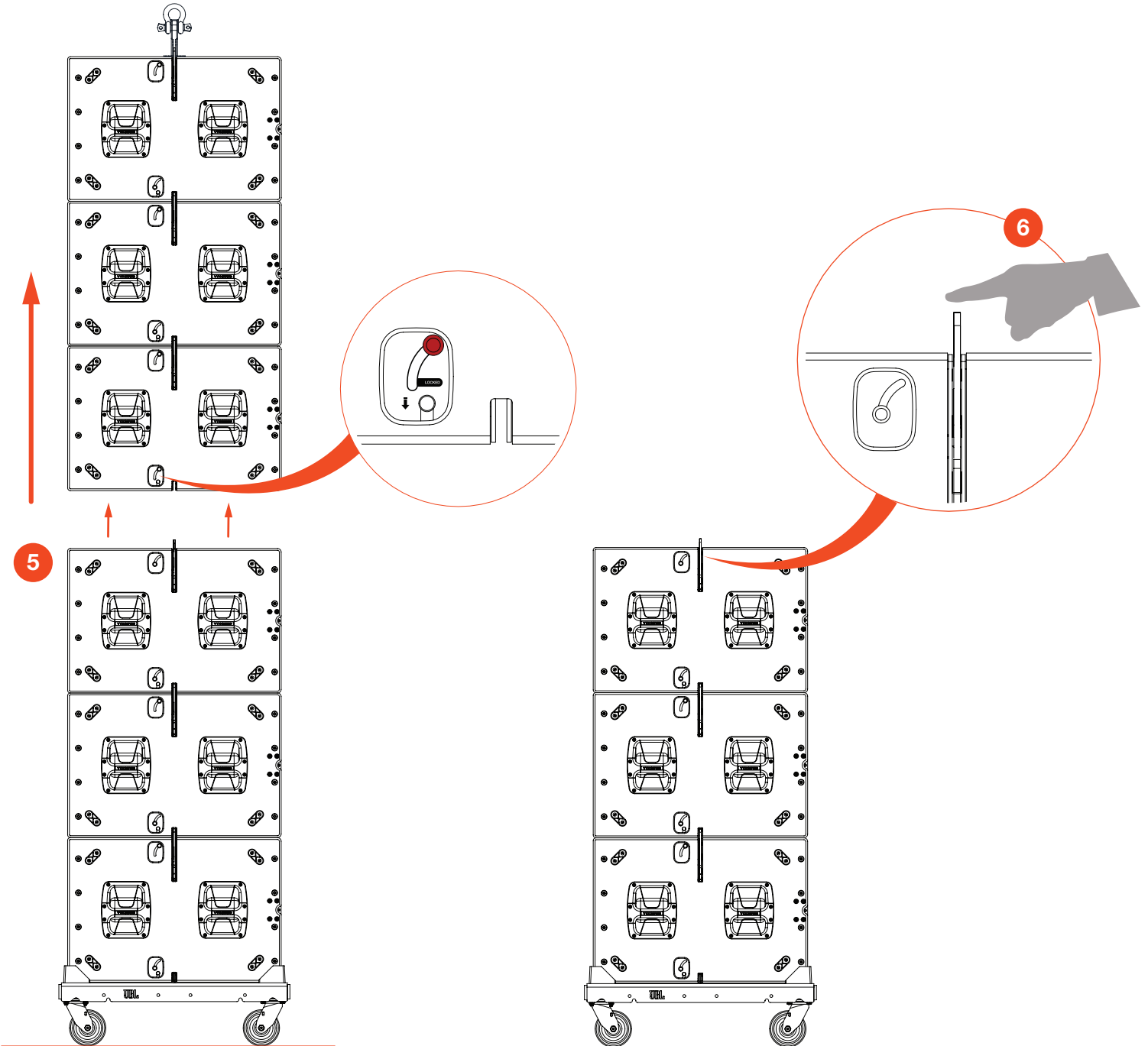

**9.4 SUSPENSION BAR USE CASES**

The VTX B28 Suspension Bar can be deployed in both dual-point and single-point configurations as illustrated below. The mechanical capacity of the suspension bar is the same for both configurations (16 B28) but a higher safety factor is realized in dual-point setups. Consult the LAC-3 software application for actual safety factors for a given array.

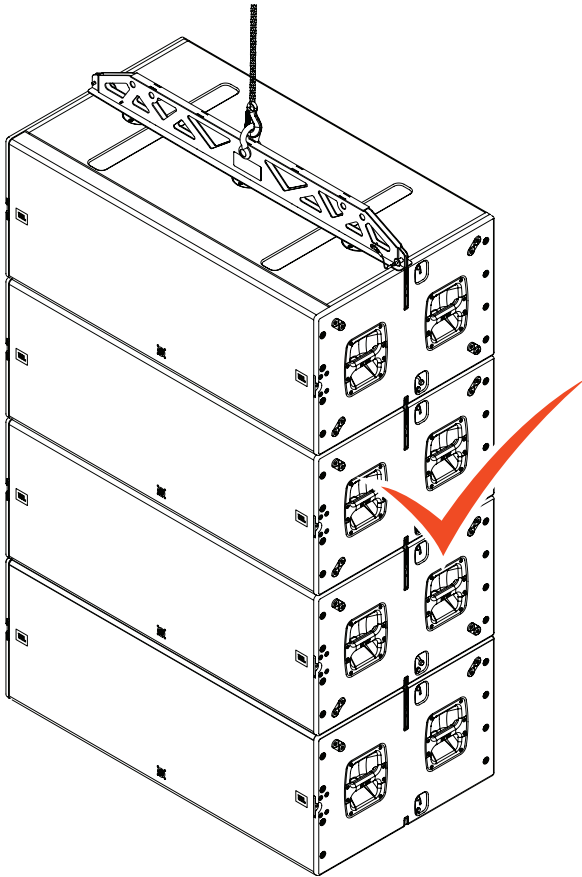

SINGLE SUSPENSION BAR  
SINGLE-POINT

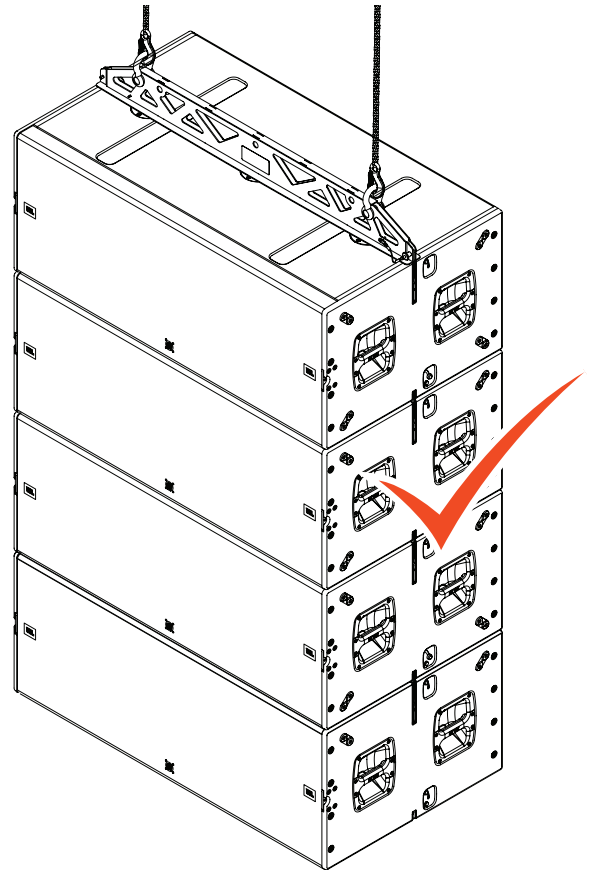

SINGLE SUSPENSION BAR  
DUAL-POINT | SIDE-BY-SIDE

**9.5 SUSPENSION BAR SAFETY POINTS**

The VTX B28 Suspension Bar includes two additional 5/8-inch shackle positions that can be used to facilitate secondary safety attachments for installations or regions requiring such safety measures. The safety points are rated for the same load as the main attachment points and assume static load conditions. It is the responsibility of the installer/user to make sure the array hardware and all other safety hardware are rated for the exact use case and requirements.

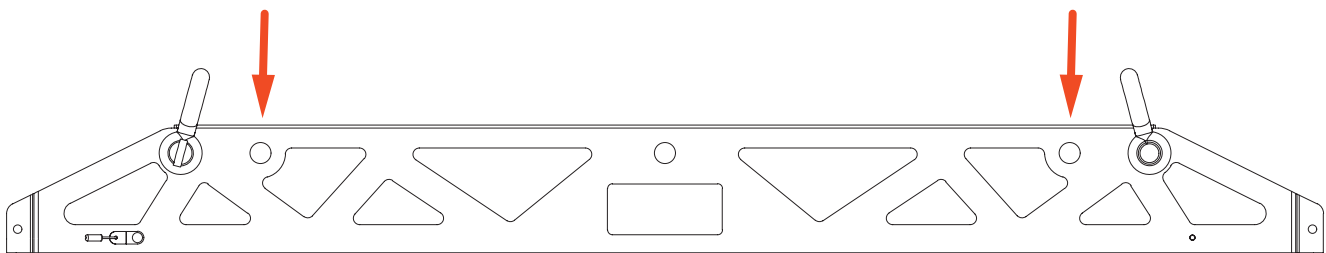

## 10 - THE VTX B28 GND

The VTX B28 GND is an outrigger accessory that improves stability in ground stack configurations built on the VTX B28 subwoofer. The B28 GND connects directly to the B28's integral rigging hardware and enlarges the base footprint of the stack. The B28 GND can be used with B28-only ground stacks of more than four enclosures, or when full-range VTX speakers are stacked on top of B28 subwoofers using one of the supported base plate accessories. The B28 GND enables semi-permanent attachment of B28s to stages, carts, and other support structures, using its M10 through-holes. The two-part design is compact, lightweight, and fits into most standard road cases.

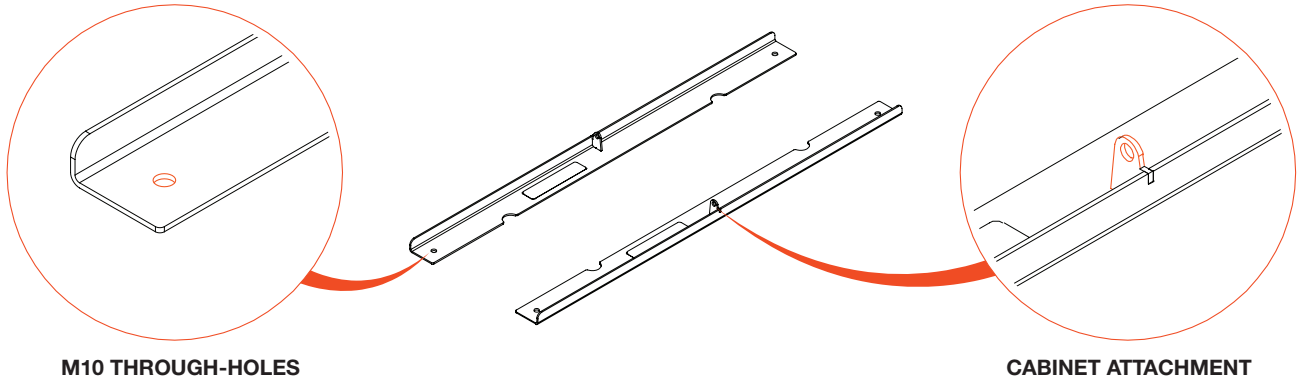

### 10.1 ATTACHING THE VTX B28 GND

Attaching the VTX B28 GND is very easy and should be done while the B28 is still on the ACC. First remove the soft cover, open the locks, and attach both outriggers. Once the GND is attached, use the rear two handles to flip the cabinet onto the GND. Then, remove the ACC dolly and stack any additional B28s. Perform the same steps in reverse to disassemble.

#### STEPS:

- 1 Remove the soft cover and attach the two outriggers.
- 2 Use the rear two handles to flip the B28 onto the GND.
- 3 Remove the ACC dolly. Additional B28 cabinets can be stacked on top, if needed.

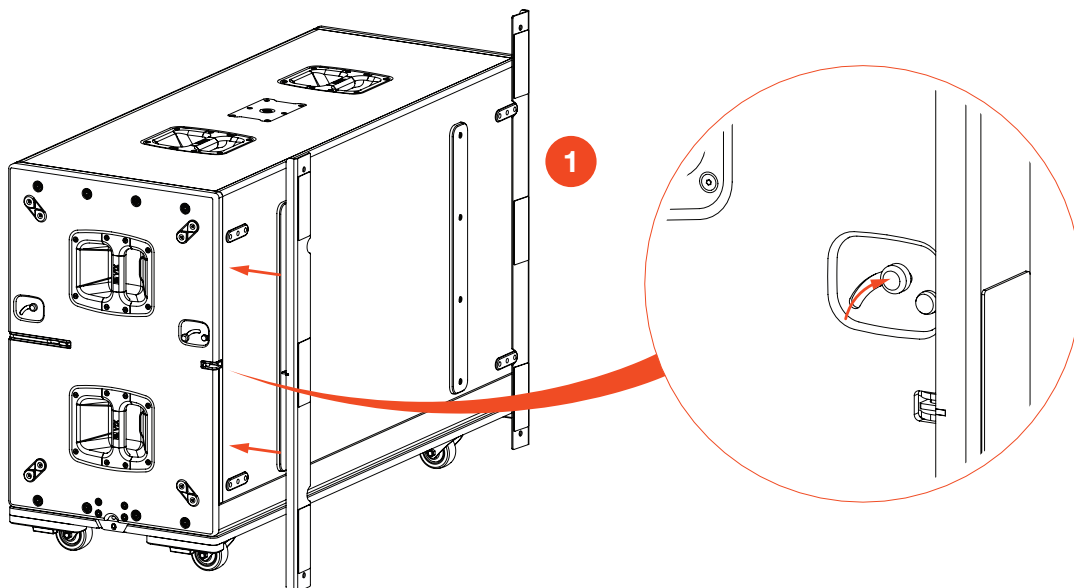

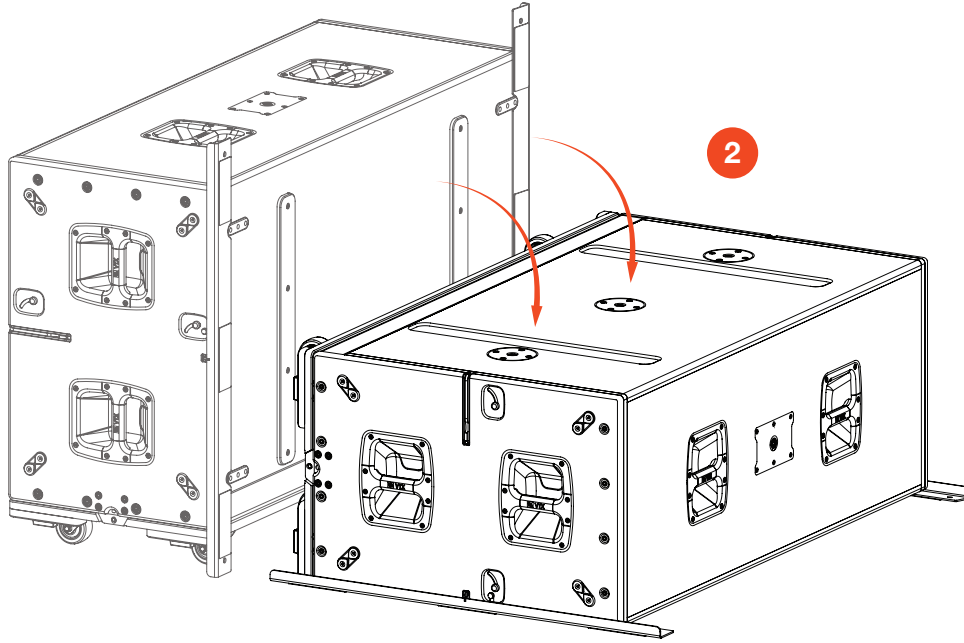

**10.2 VTX B28 GND EXAMPLES**

Below are some examples showing the VTX B28 GND being used with supported base plates like the VTX A8 BP and VTX A12 BP. Base plates attach to the M20 mount plates at the top of the B28. For more information on installing base plates, refer to the Rigging Manuals for the appropriate systems.

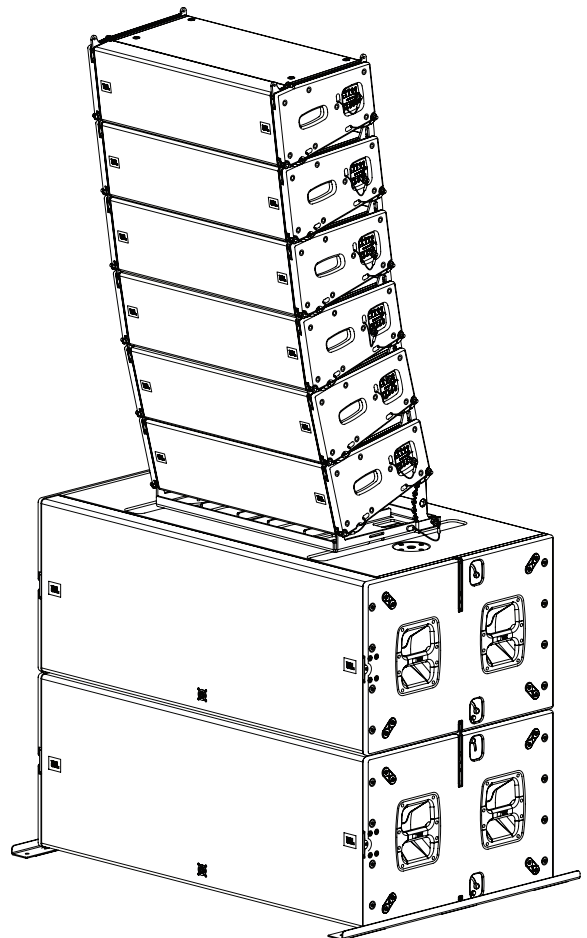
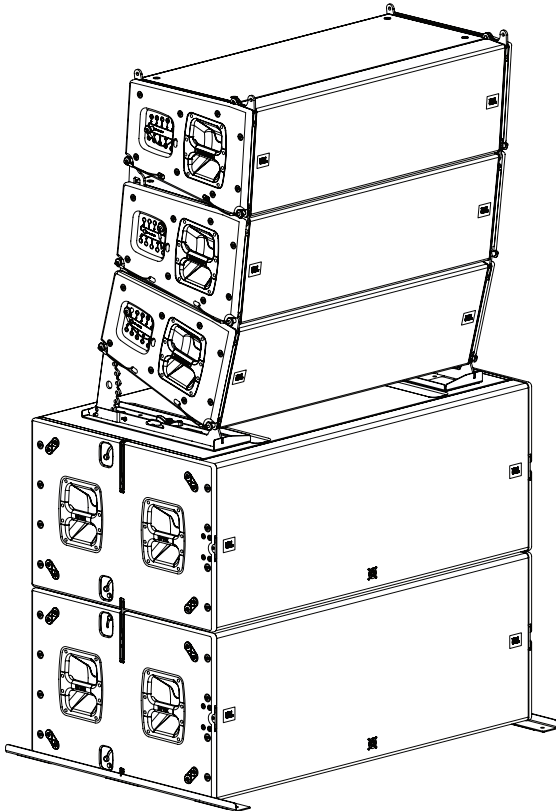

## 11 - THE VTX A12 VT GND

The VTX A12 VT GND outrigger system works in conjunction with compatible Vertical Transporter carts to improve stability in ground stack configurations. The two outriggers extend in front of and behind the stack and connect to the VT using the included quick release pins. Screw jacks are used to lift the stack off the ground, while innovative spring-based, angle set hinges adjust overall aiming. The GND includes a hinge mechanism, which is usually used to aim an array. In the case of the B28, the VTX A12 VT GND is always used at the default 0-degree (storage) position, and only to enhance stability, not to aim. For more details on the VTX A12 VT GND refer to the VTX A12 Rigging Manual.

### 11.1 ATTACHING THE VTX A12 VT GND

The VTX A12 VT GND was designed to attach to the Vertical Transporter without having to remove the cabinets from the cart. When the screw jacks are set to their lowest position, the outriggers are shorter than the VT and easily slide under the stack. The front to back orientation of the GND is not relevant in this use case and can attach to the VT in either direction.

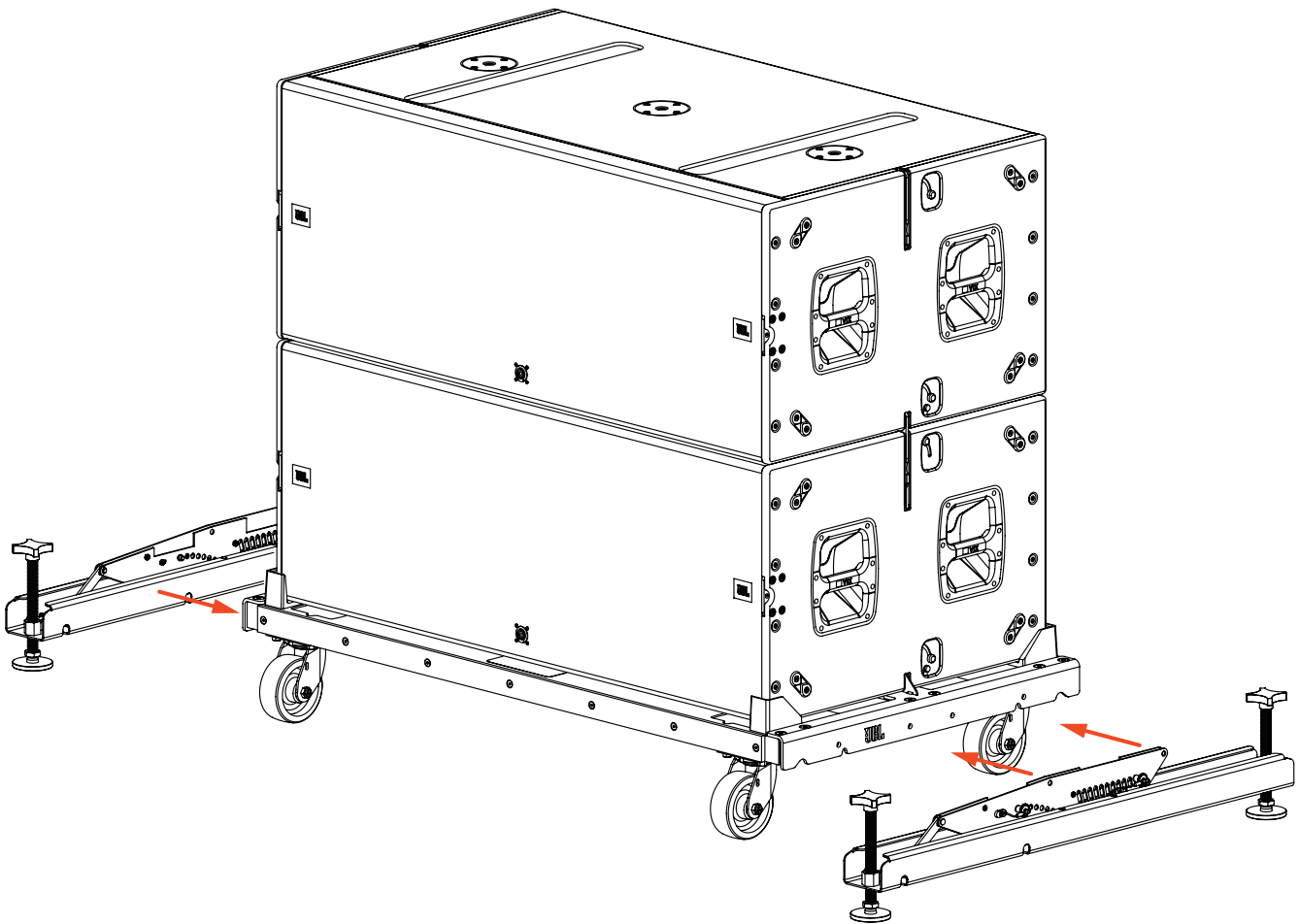

**CAUTION:** In this use case, the two quick release pins already set in the marked storage positions should never be removed. Releasing these two QRPs engages the spring-loaded aiming mechanism, which is used for the A12, but not the B28.

Once the outriggers are under the VT, remove the two quick release pins labeled **FRONT** and **REAR** VT Connection Points and attach the outriggers. **The two QRPs in the storage positions should remain there; they are never used in this application.**

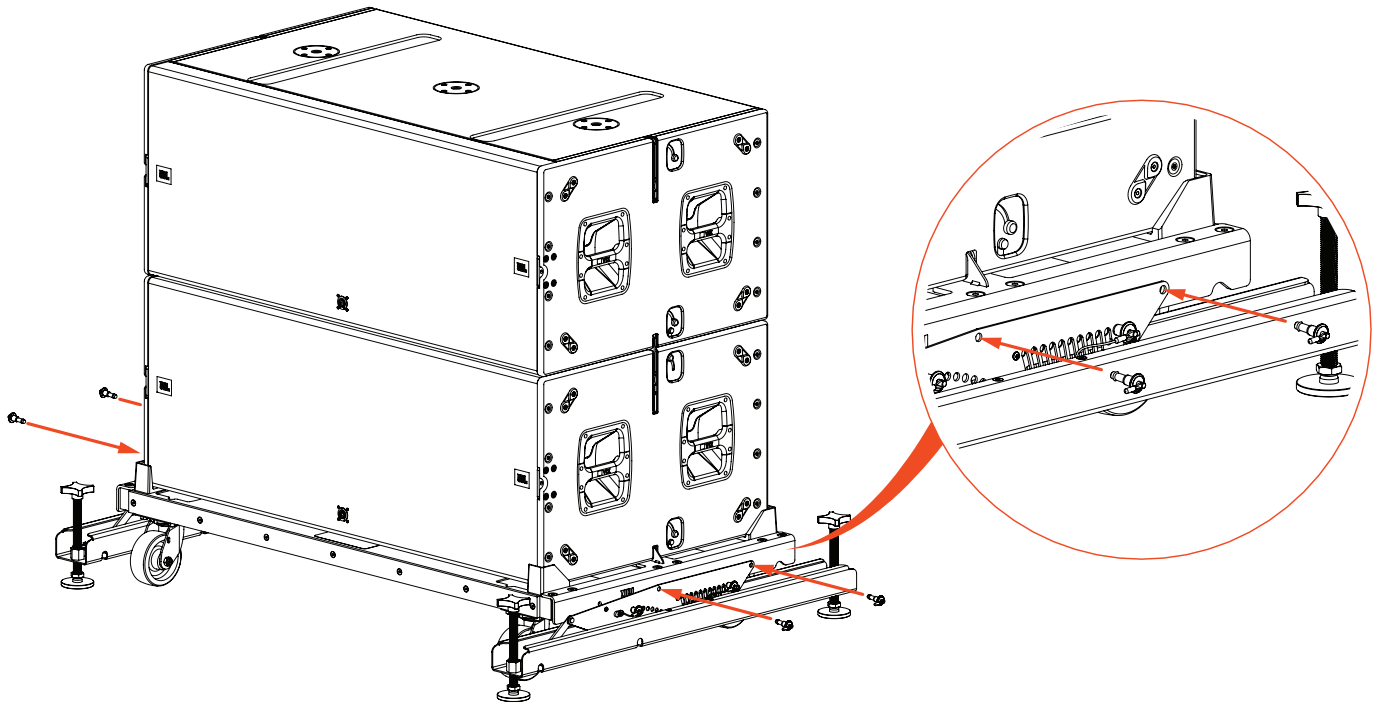

Once all the parts are together, the screw jacks are used to lift the stack off the ground. The screw jacks are used only to ensure that the array is not on wheels, not to aim it. Use the handles at the very top of the screw jacks to lift the array at all four corners. Continue rotating until the wheels of the VT are off the ground.

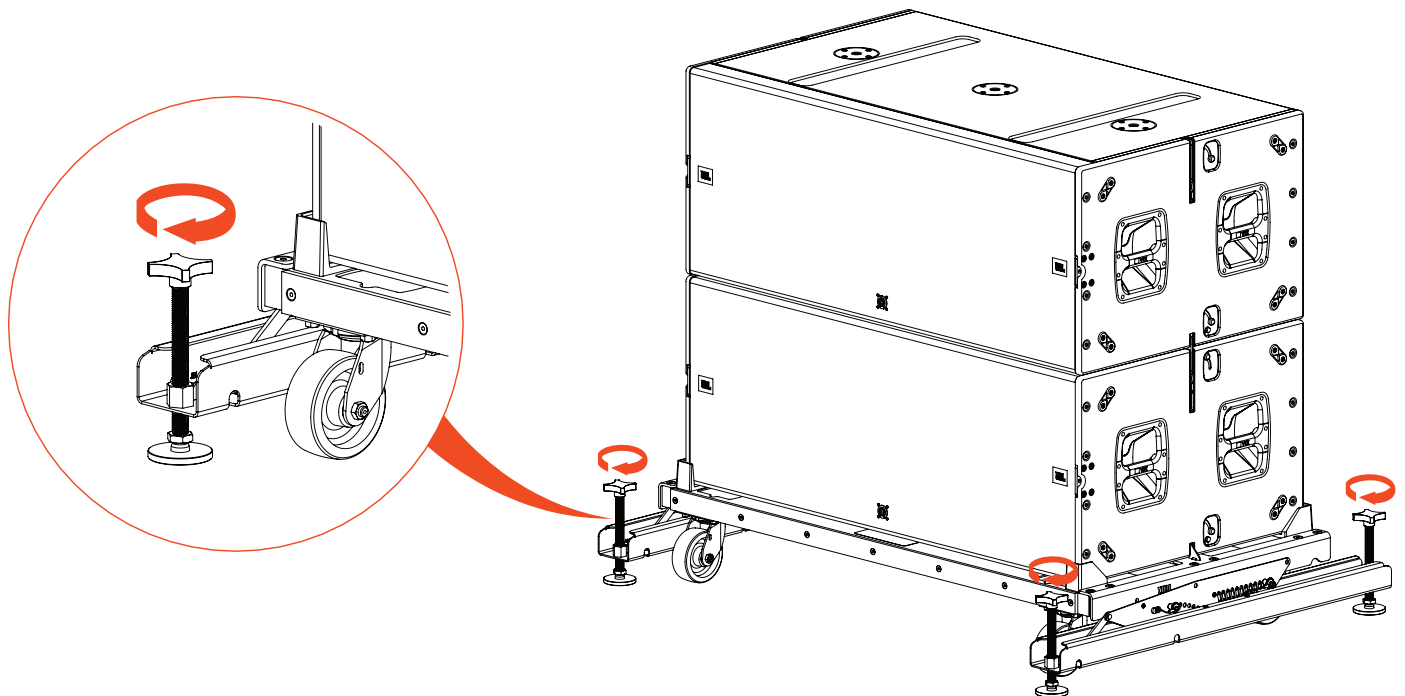

Once the stack is stable and off the wheels, additional subwoofers or other products can be attached to the B28s using supported base plates. To disassemble the array and remove the outriggers, follow the same steps in reverse order.



11.2 VTX B28 GND + VTX A12 VT GND EXAMPLES

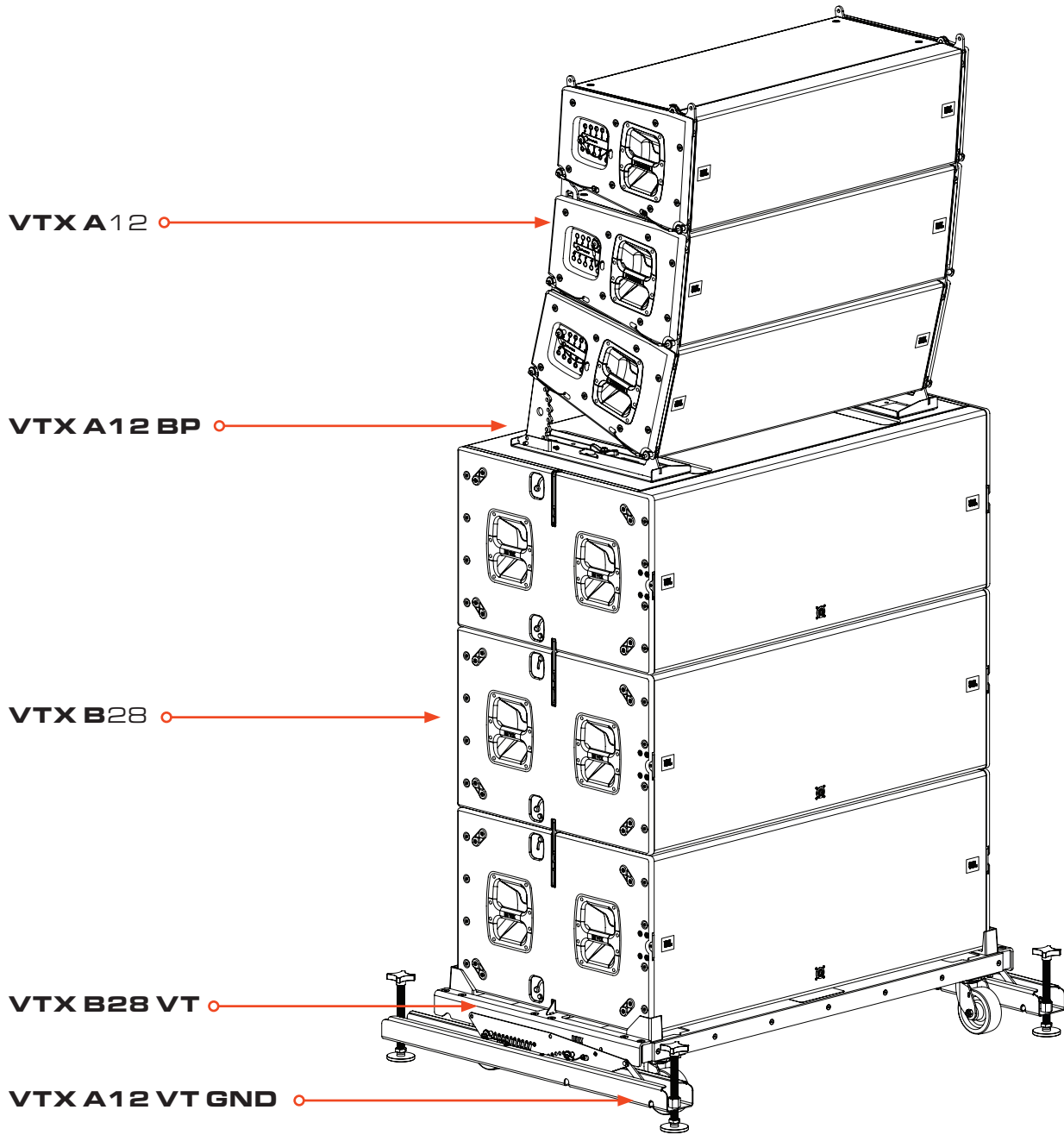

**CAUTION:** Always use Line Array Calculator 3 software to validate the mechanical integrity and stability of VTX arrays, including ground stack systems and accessories. Note that calculations in LAC-3 always assume flat, even ground and ideal conditions. Always use good judgment and best practices to assemble arrays. JBL Professional recommends that all ground stack arrays be secured to the ground, even when the configuration is shown as safe in LAC-3.

## 12 - USING THE M20 POLE MOUNT ATTACHMENT

The B28 includes standard M20 pole mount plates for attaching extension rods such as the JBL SS5-BK or other JBL supported accessories like base plates. This allows using the B28 subwoofer with a number of JBL full-range speakers like the VTX F12/F15 or VRX series products. In this configuration, a load of up to **45kg (100lbs)** can be placed on the extension rod as a static vertical load.

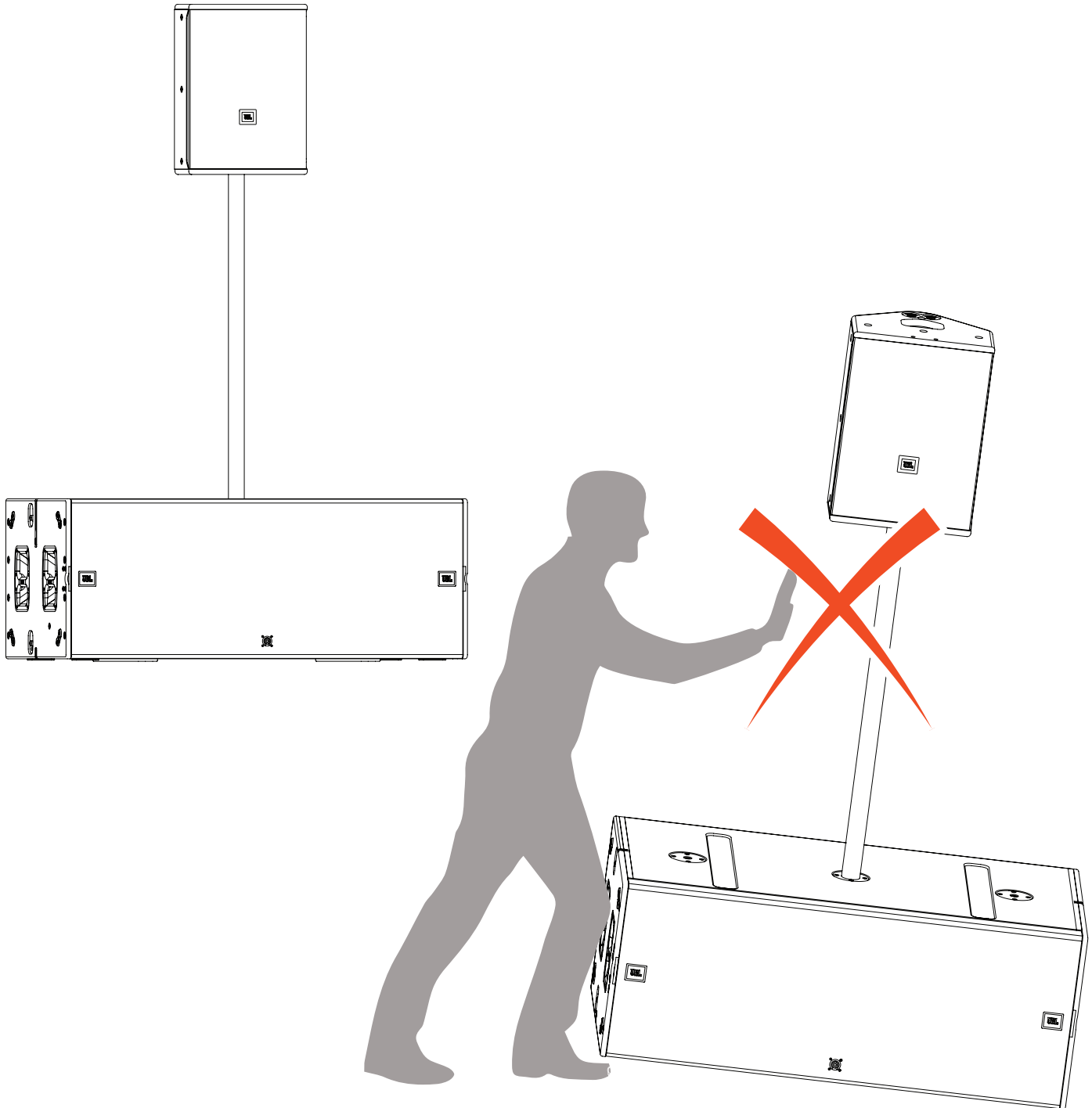

**CAUTION:** Lifting or pushing the extension rod, or sliding the B28 with a loaded extension rod, is unsafe. This can result in permanent damage or reduce the capacity of the M20 plate, potentially leading to a falling loudspeaker and personal injury.

## 13 - SPECIFICATIONS

### 13.1 VTX B28 SB

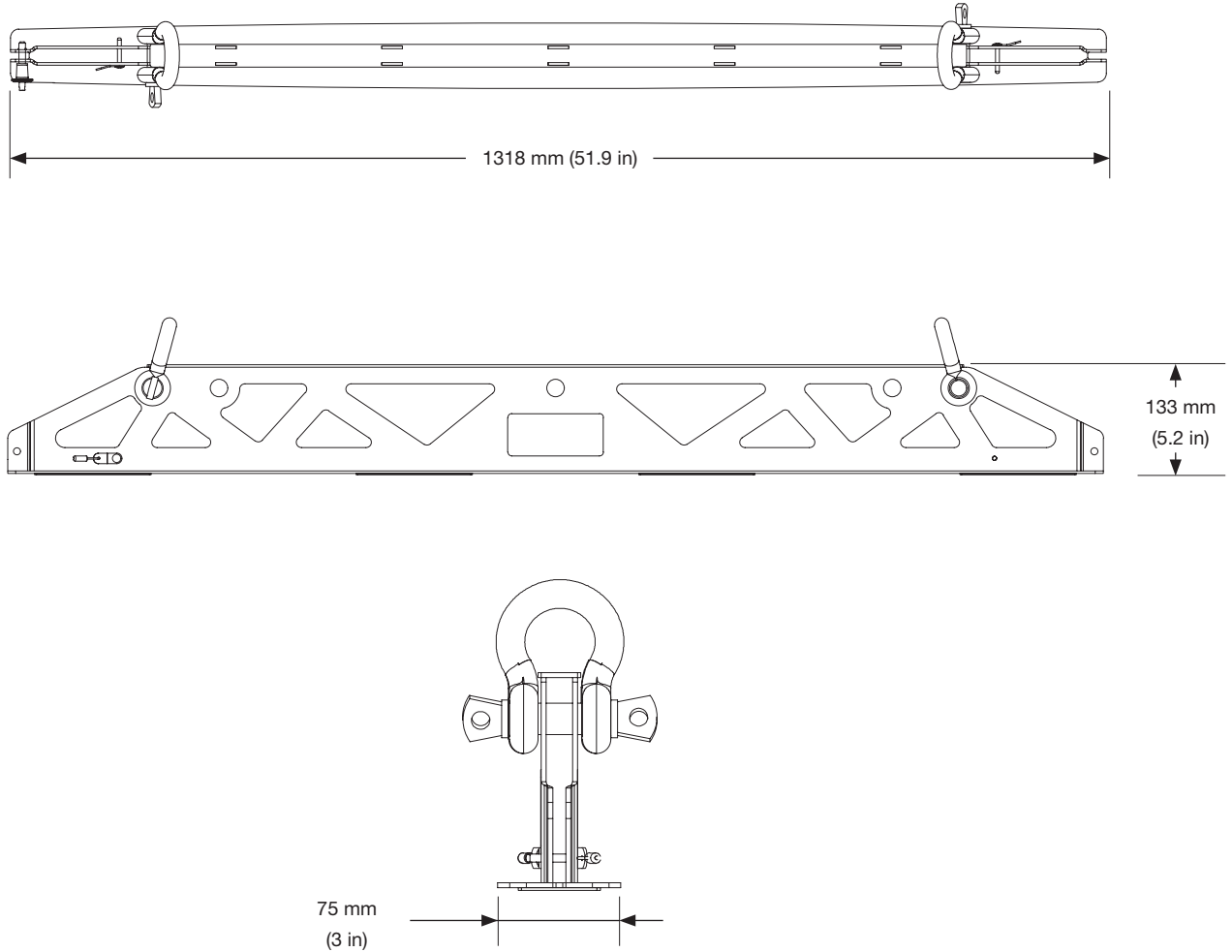

**Construction:** High-grade steel with anti-corrosion coating

**Finish:** Black powder coat

**Compatible Shackle Size:** 5/8 inch

**Mechanical Limits<sup>1</sup>**

**Maximum:** (16) VTX B28

**Safe Limit:** (16) VTX B28

**Dimensions (H x W x D)<sup>2</sup>:** 133 mm x 1318 mm x 75 mm  
(5.2 in x 51.9 in x 3 in)

**Net Weight<sup>3</sup>:** 8.2 kg (18.2 lbs)

**Footnotes:**

1: Always check mechanical safety with JBL LAC-3 prediction software. For more information on SB mechanical limits, please refer to the VTX B28 Rigging Manual.

2: Refer to the 2D and 3D Customer Drawings for more detailed dimensions.

3: Shackles and other rigging parts are not included.

JBL continually engages in research related to product improvement. Some materials, production methods and design refinements are introduced into existing products without notice as a routine expression of that philosophy. For this reason, any current JBL product may differ in some respect from its published description, but will always equal or exceed the original design specifications unless otherwise stated.

**13.2 VTX B28 ACC**

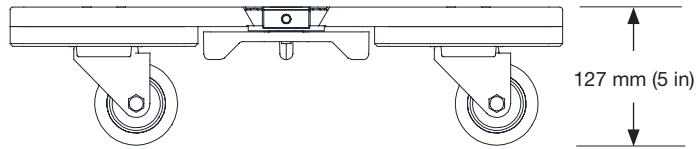
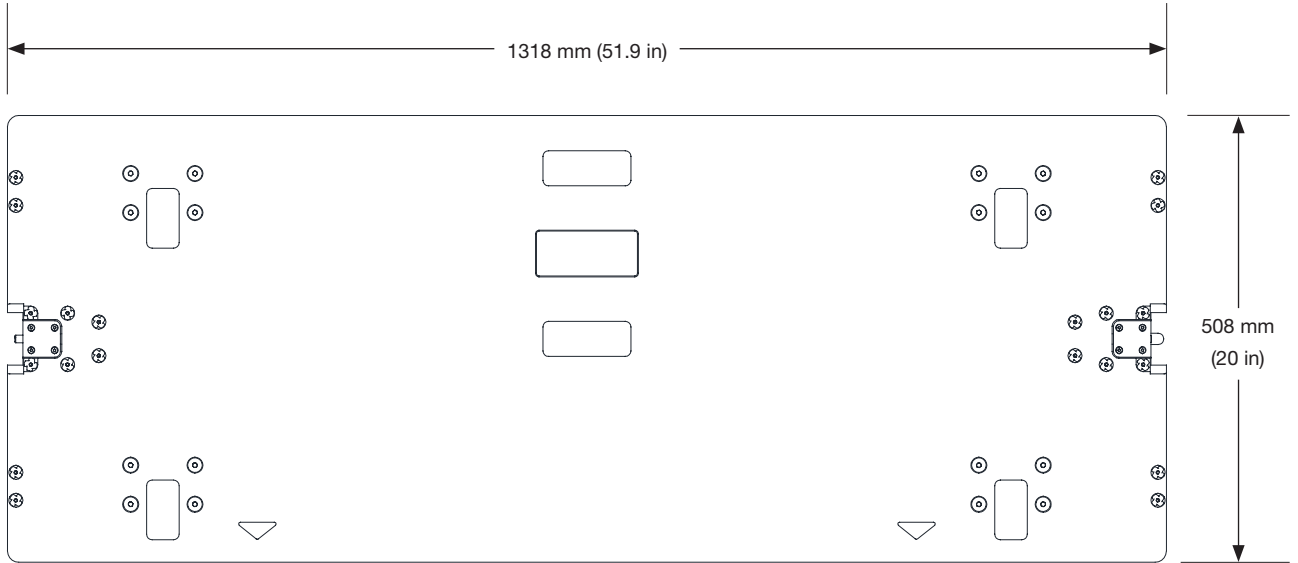

**Construction:** Exterior-grade birch plywood with stainless steel/zinc plated steel hardware

**Finish:** Black JBL Duraflex™ finish

**Dimensions (H x W x D)<sup>1</sup>:** 127 mm x 1318 mm x 508 mm  
(5 in x 51.9 in x 20 in)

**Net Weight<sup>2</sup>:** 12.8 kg (28.3 lbs)

**Footnotes:**

- 1: Refer to 2D and 3D Customer Drawings for more detailed dimensions.
- 2: Weight includes caster board and soft cover.

JBL continually engages in research related to product improvement. Some materials, production methods and design refinements are introduced into existing products without notice as a routine expression of that philosophy. For this reason, any current JBL product may differ in some respect from its published description, but will always equal or exceed the original design specifications unless otherwise stated.

**13.3 VTXB28 VT**

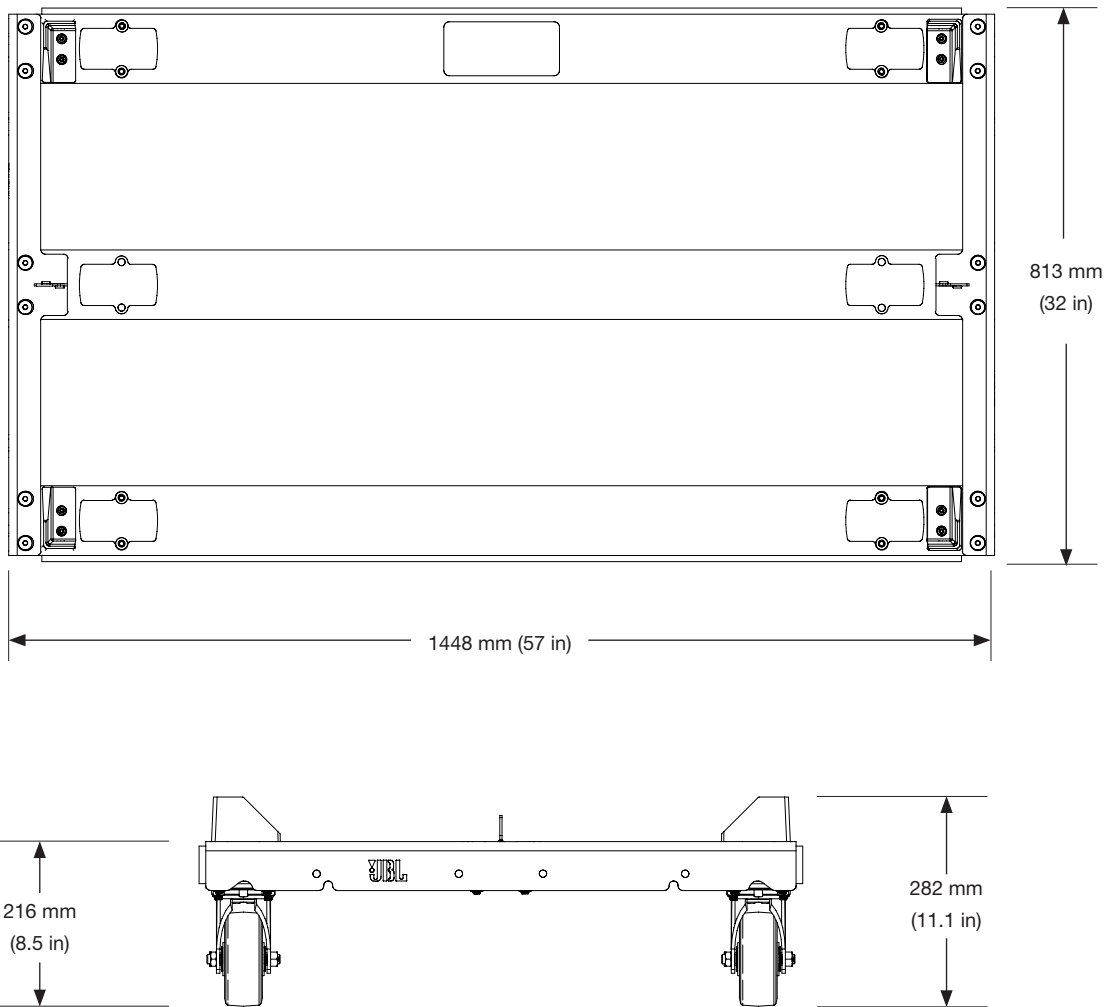

**Construction:** High-grade steel with anti-corrosion coating and black anodized aluminum

**Finish:** Black Powder coat

**Mechanical Limits**

**Maximum:** (4) VTX B28

**Dimensions (H x W x D)<sup>1</sup>:** 282 mm x 1448 mm x 813 mm  
(11.1 in x 57 in x 32 in)

**Net Weight<sup>2</sup>:** 35 kg (77.2 lbs)

**Footnotes:**

- 1: Refer to the 2D and 3D Customer Drawings for more detailed dimensions.
- 2: Weight includes the VTX B28 VT only. Soft cover not included.

JBL continually engages in research related to product improvement. Some materials, production methods and design refinements are introduced into existing products without notice as a routine expression of that philosophy. For this reason, any current JBL product may differ in some respect from its published description, but will always equal or exceed the original design specifications unless otherwise stated.

**13.4 VTX B28 GND**

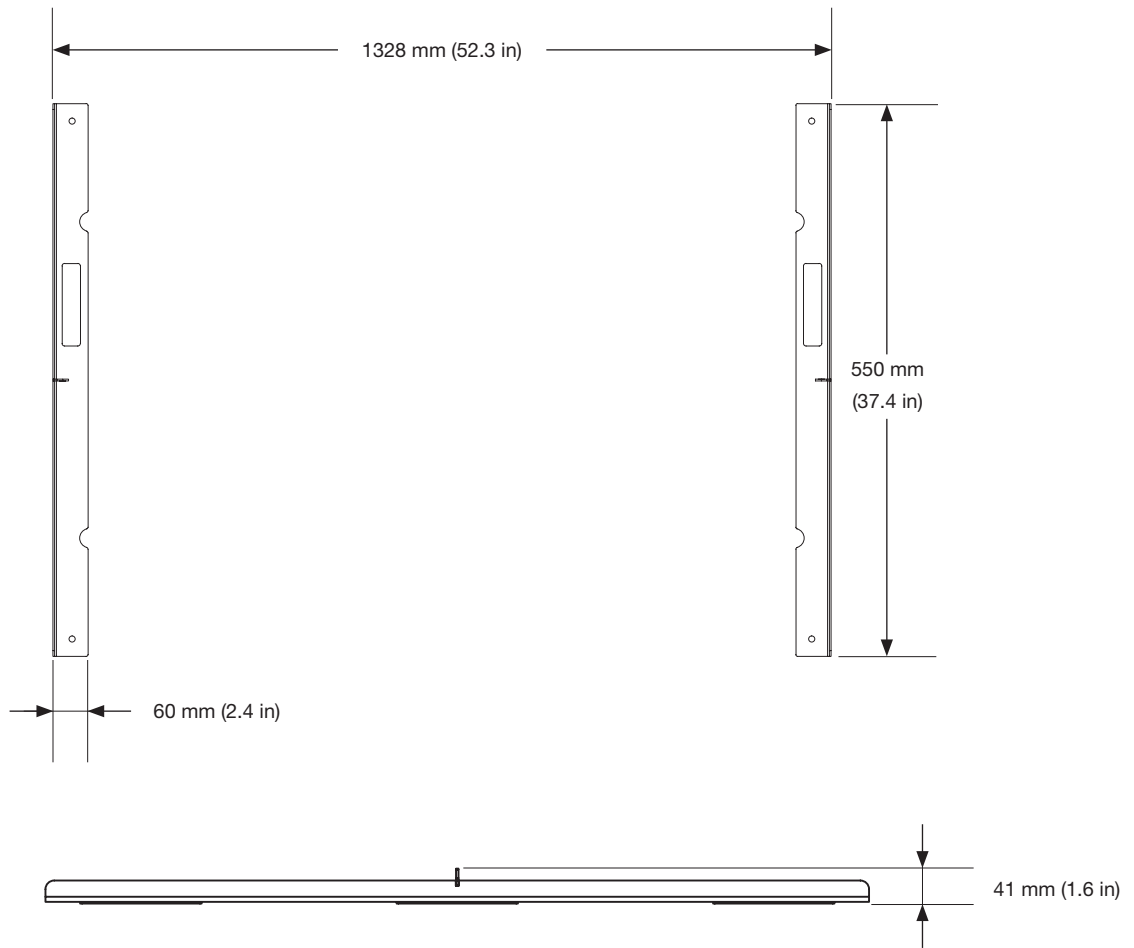

**Construction:** High-grade steel with anti-corrosion coating

**Finish:** Black Powder Coat

**Dimensions (H x W x D):** 41 mm x 60 mm x 550 mm  
(1,6 in x 2.4 in x 37.4 in)

**Net Weight<sup>3</sup>:** 3.7 kg (8.3 lbs)

**Footnotes:**

- 1: For arrays larger than the safe limit always use JBL Line Array Calculator software to determine mechanical safety.
- 2: Refer to 2D and 3D Customer Drawings for more detailed dimensions.
- 3: Net weight refers to one complete set of outriggers (left/right).

JBL continually engages in research related to product improvement. Some materials, production methods and design refinements are introduced into existing products without notice as a routine expression of that philosophy. For this reason, any current JBL product may differ in some respect from its published description, but will always equal or exceed the original design specifications unless otherwise stated.

## 14 - CONTACT INFORMATION

### UNITED STATES OF AMERICA

#### HARMAN Professional Solutions

8500 Balboa Blvd.  
Northridge, CA 91329  
USA  
+1 (844) 776-4899  
[www.jblpro.com](http://www.jblpro.com)

#### U.S.A. Technical Support

+1 (800) 852-5776  
[HProTechSupportUSA@Harman.com](mailto:HProTechSupportUSA@Harman.com)  
[www.jblpro.com](http://www.jblpro.com)

### PROFESSIONAL CONTACTS, OUTSIDE THE U.S.A.:

Contact the JBL Professional Distributor in your area. A complete list of JBL Professional international distributors is provided at our U.S.A. website: [www.jblpro.com](http://www.jblpro.com)

#### HARMAN Professional EMEA

Westside  
London Road  
Hemel Hempstead  
HP3 9TD  
United Kingdom  
[www.pro.harman.com](http://www.pro.harman.com)  
[www.jblpro.com/support](http://www.jblpro.com/support)

#### HARMAN Professional APAC

108 Pasir Panjang Road  
#02-08 Golden Agri Plaza  
Singapore 118535  
+65 6870-5000  
[www.pro.harman.com](http://www.pro.harman.com)  
[www.jblpro.com/support](http://www.jblpro.com/support)

#### HARMAN Professional China

20F, China Merchants Port Plaza, #1  
Gongye 3rd Road, Shekou, Nanshan  
Dist.  
Shenzhen, 518067, China  
400 166 7806  
[www.harman.com/China](http://www.harman.com/China)

#### China In-Country Support

[ChinaPRO.Service@harman.com](mailto:ChinaPRO.Service@harman.com)

#### HARMAN Professional India

Prestige Technology Park  
Jupiter 2A Block, 4th Floor  
Marathahalli Ring Road  
Bangalore 560103, India  
+1 (800) 208-8880  
[www.harman.com/India](http://www.harman.com/India)

#### HARMAN Professional Brazil

Br386, Km435 92480-000  
Nova Santa Rita Rs  
Brazil  
+55 51 34794000  
[www.harman.com/Brasil](http://www.harman.com/Brasil)  
[www.jblaudio.com.br](http://www.jblaudio.com.br)

#### India In-Country Support

[www.harman.com/india/india-service-center](http://www.harman.com/india/india-service-center)

#### Brazil In-Country Support

[tecnica@harman.com](mailto:tecnica@harman.com)

**JBL**

**PROFESSIONAL**